

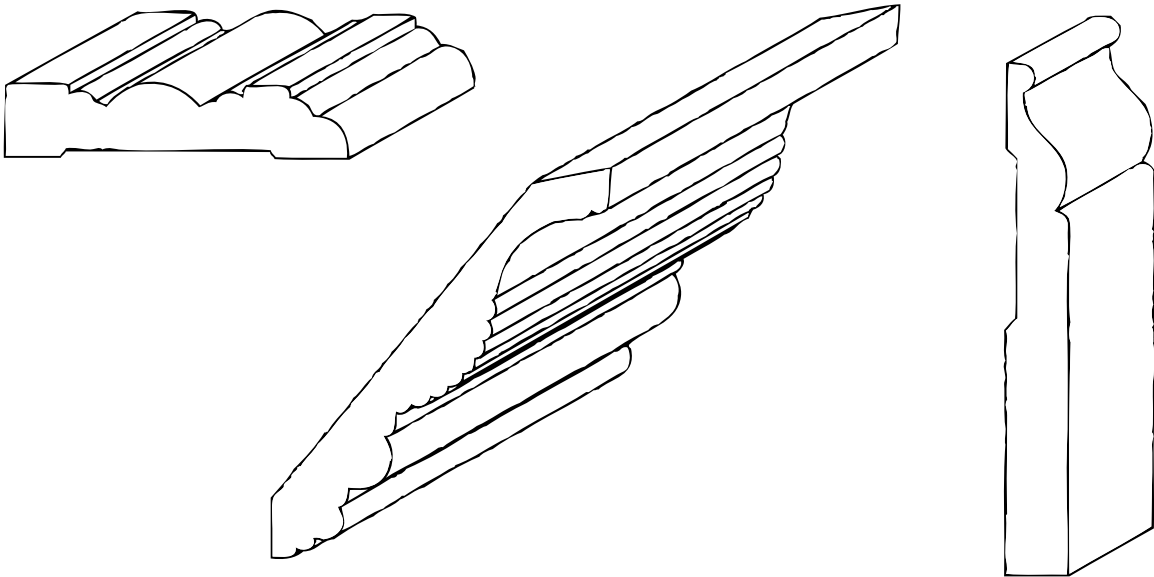

"Striving to be the Best in Interior Millwork."

Molding Catalog



Corporate Office
3025 Highway 90 Bronston, Kentucky 42518
Phone: (606) 561-4242 Fax: (606) 561-4379
www.cumberlandtdd.com

RETURNED MERCHANDISE

No Merchandise Shall Be Returned Without Approval Of Cumberland Millwork. Although We Are Constantly "Striving To Be The Best In Interior Millwork" We Do Make Mistakes. Goods To Be Found Defective Or Damaged In Shipping Will Be Replaced Or Credited To The Clients Account. Material That Has Been Modified In Any Way Will Not Be Accepted For Credit. Items That Have Been Custom Made May Not Be Returned For Credit. Custom Ground Profiles Or Non-stock Profiles Are Not Allowed For Return. All Custom Ground And Non-stock Profiles Are Applicable To A 10% Overage Of The Run. Excess Material May Be Returned If It Is In Good Condition And In Usable Lengths.

LIMITED WARRANTY

All Of Cumberland Millwork Products Have A Warranty To Be Free Of Defects Which Render An Unserviceable Circumstance In Which It Was Intended. Natural Variation Of The Wood In Color Or Texture Are Not Considered To Be Defects.

Any Implied Warranties Which The Purchaser May Have Are Limited In Duration To 1 (one) Year From The Date Of Shipment.

EXCLUSIONS

The Warranty Listed Above Complies With Recommended Finishing And Installation. Including But Not Limited To The Following:

1. Material Being Stored In A Damp Location.
2. Material Must Be Finished In A Timely Manner.
3. Material Should Not Be Subjected To Extreme Heat Or Dryness.

ALLEVIATIONS

Should Material Be Proven To Be Defective In The Allotted Time, Cumberland Millwork Shall Do One Or All Of The Following:

1. Repair At No Charge.
2. Replace At No Charge.
3. Refund The Purchase Price.

In No Event Shall Cumberland Millwork Pay For The Cost Of Labor, Installation Or Finishing Of The Replacement Product, Or For Any Other Cause Relating To The Replacement Of The Product.

We at *Cumberland Millwork & Supply* would like to thank you for considering us as your interior millwork supplier. We assure you that we use only the best sources to offer you top of the line moldings, doors and stairparts. With a special millwork section in our plant that is second to none, arch casings, fireplace mantels and decorative blocks are products that are produced every day. Poplar, Red Oak, Cherry and Finger Joint Poplar are readily available, with other species available with appropriate lead times.

Within this molding catalogue you will find our most frequently used profiles. If you need a custom profile ground, our tooling department will be glad to assist you with this need. After reviewing all of our catalogues, we hope that you will allow us to give you an estimate on your next job. Let *Cumberland Millwork & Supply* show you that we are constantly **"Striving to be the best in interior millwork"**.

Table of Contents

Stock Molding

Casings	4
Dentils	7
Crowns.....	8
Bases.....	11
Chair Rails.....	12
Panel Molds.....	13
Window Stools/Vee Grooves.....	14
Jambs	15
S4S Material	16
Trim Blocks	17
Crown Blocks.....	18
Doors	19
Multi-Piece Crown Samples	20

Custom Molding

Casings	21
Bases.....	27
Crowns.....	28
Chair Rails.....	31
Panel Molds.....	33

Casings

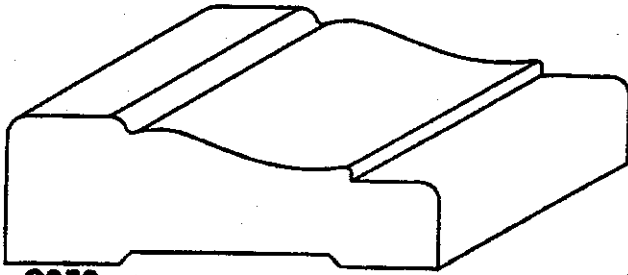

C356
3/4 X 2-1/4

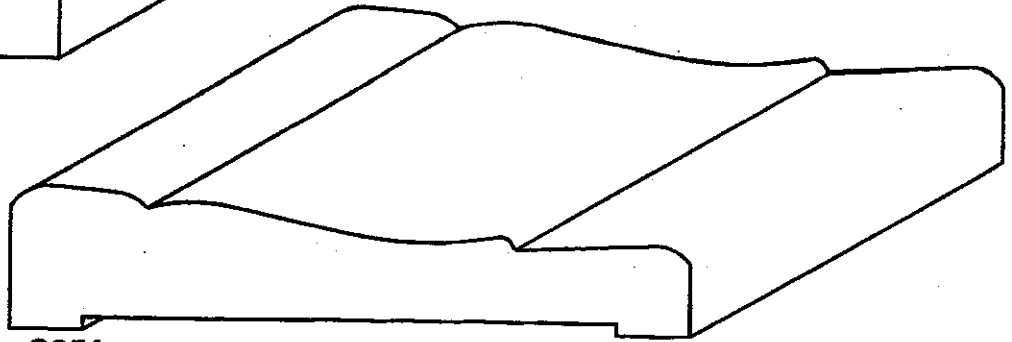

C351
3/4 X 3-1/2

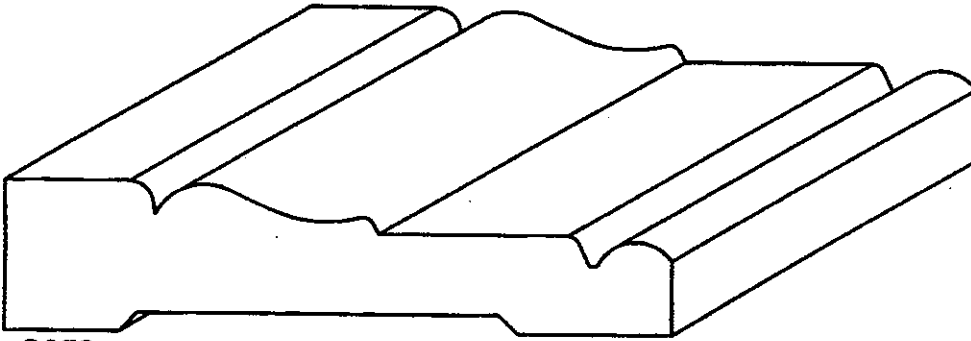

C352
3/4 X 3-1/2

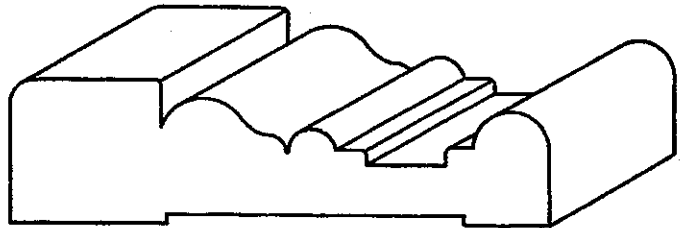

KN275
3/4 X 2-3/4

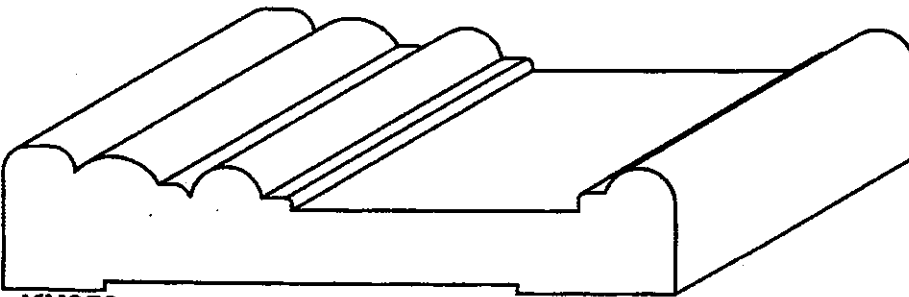

KN350
3/4 X 3-1/2

Casings

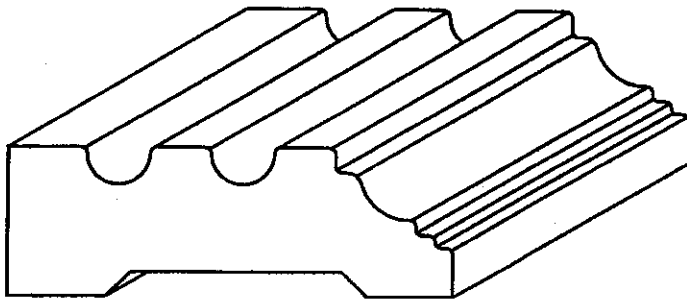

FC225
3/4 X 2-1/4

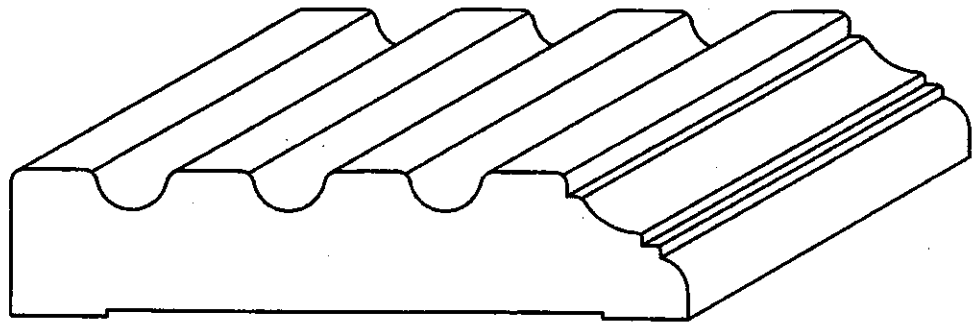

FC350
3/4 X 3-1/2

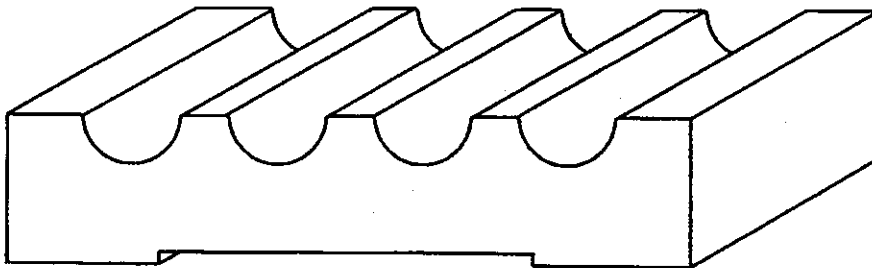

SF350
3/4 X 3-1/2

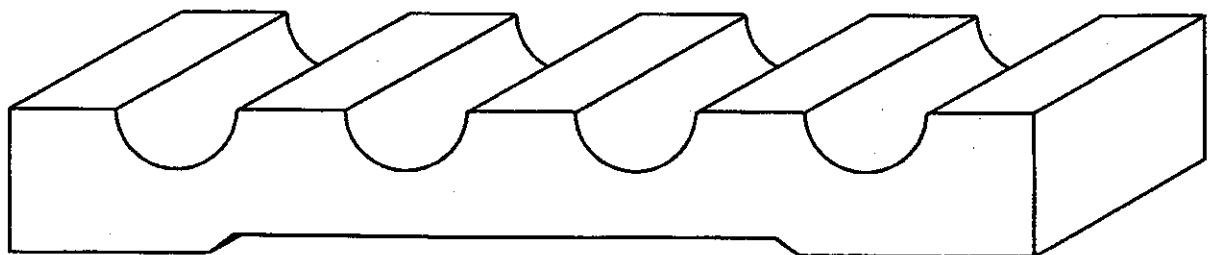

SF525
3/4 X 5-1/4

Casings

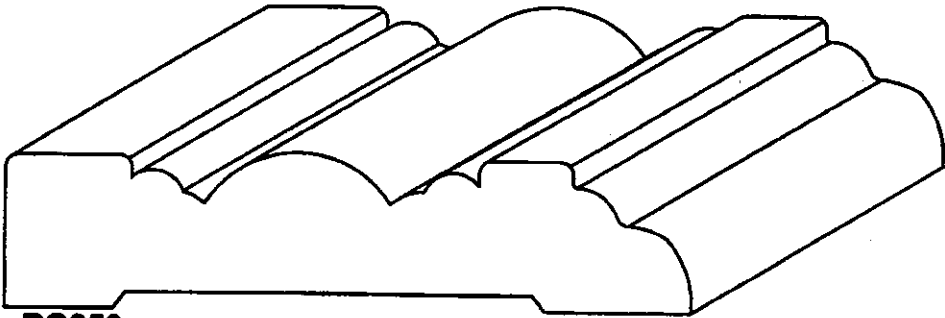

BG350
3/4 X 3-1/2

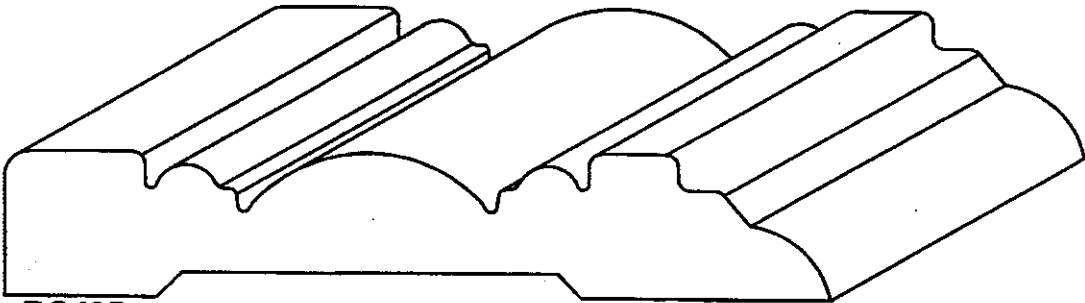

BG425
3/4 X 4-1/4

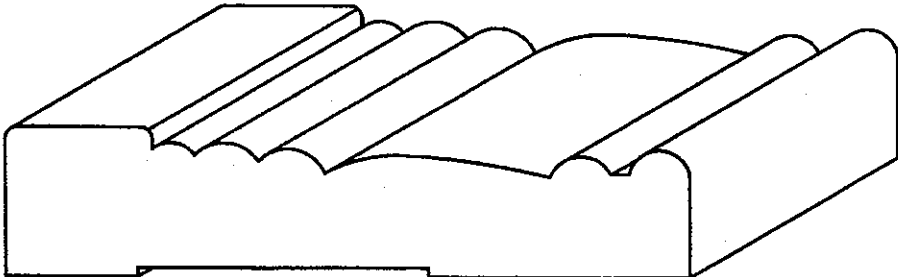

AM350
3/4 X 3-1/2

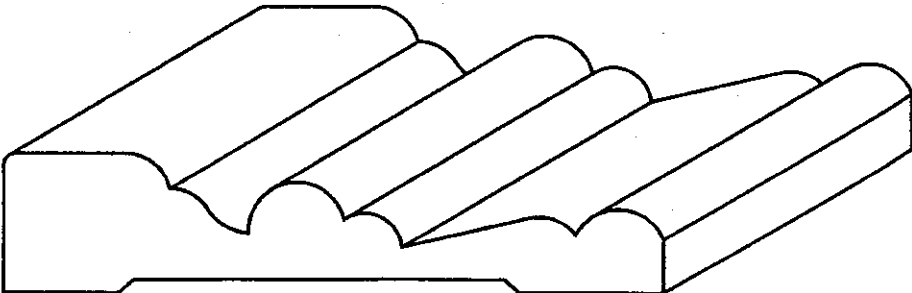

DB350
3/4 X 3-1/2

Casings

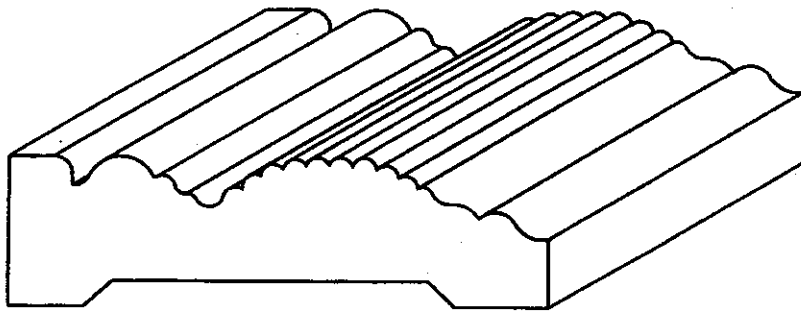

RC275
3/4 X 2-3/4

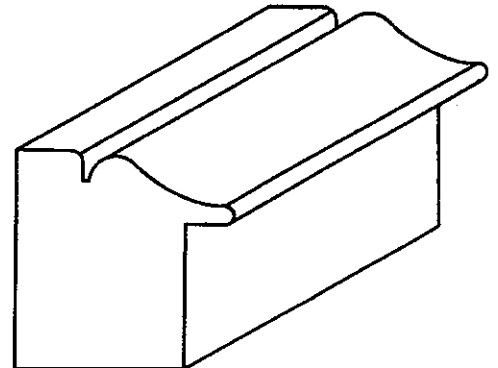

BB118
1-1/8 X 1-1/8

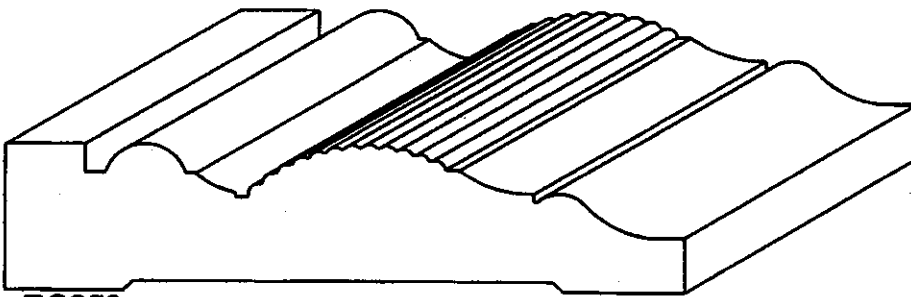

RC350
3/4 X 3-1/2

Dentils

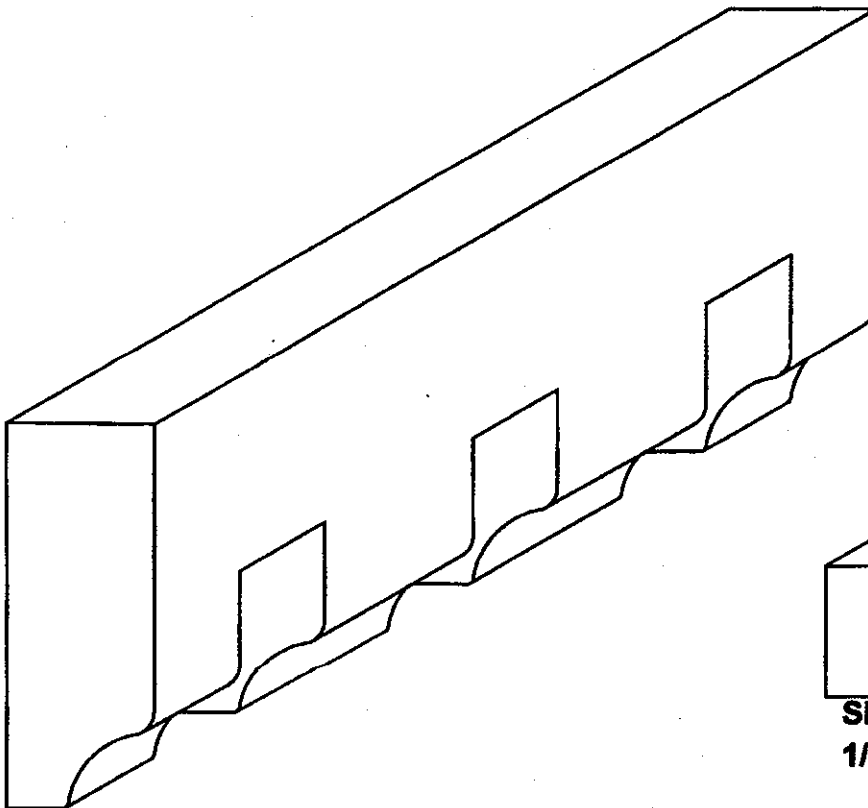

DD
3/4 X 2

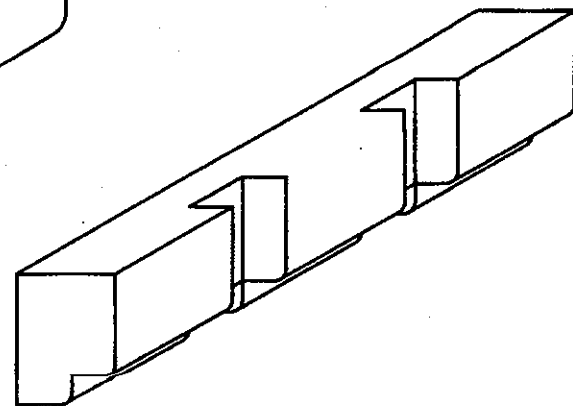

SD
1/2 X 3/4

Crowns

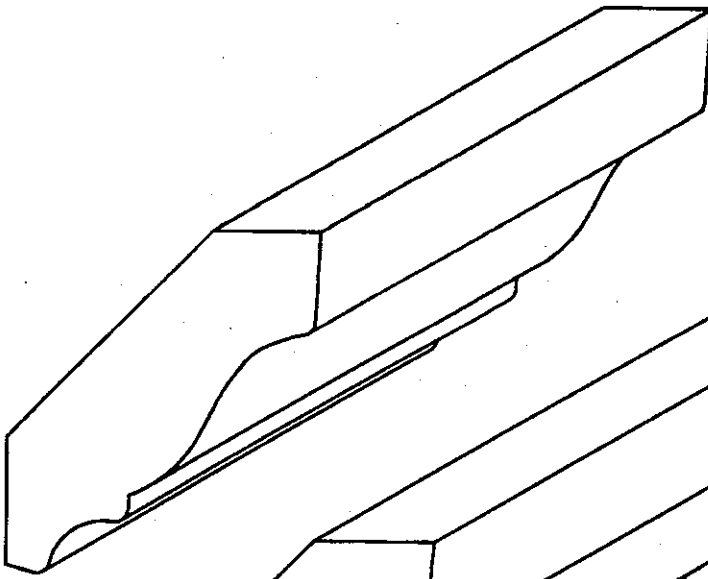

CM46
3/4 X 2-1/4

A technical drawing of a crown molding profile, labeled CM46. It shows a cross-section of a rectangular crown with a decorative, curved profile on its front face. The drawing is shown in a perspective view, highlighting the three-dimensional shape of the molding.

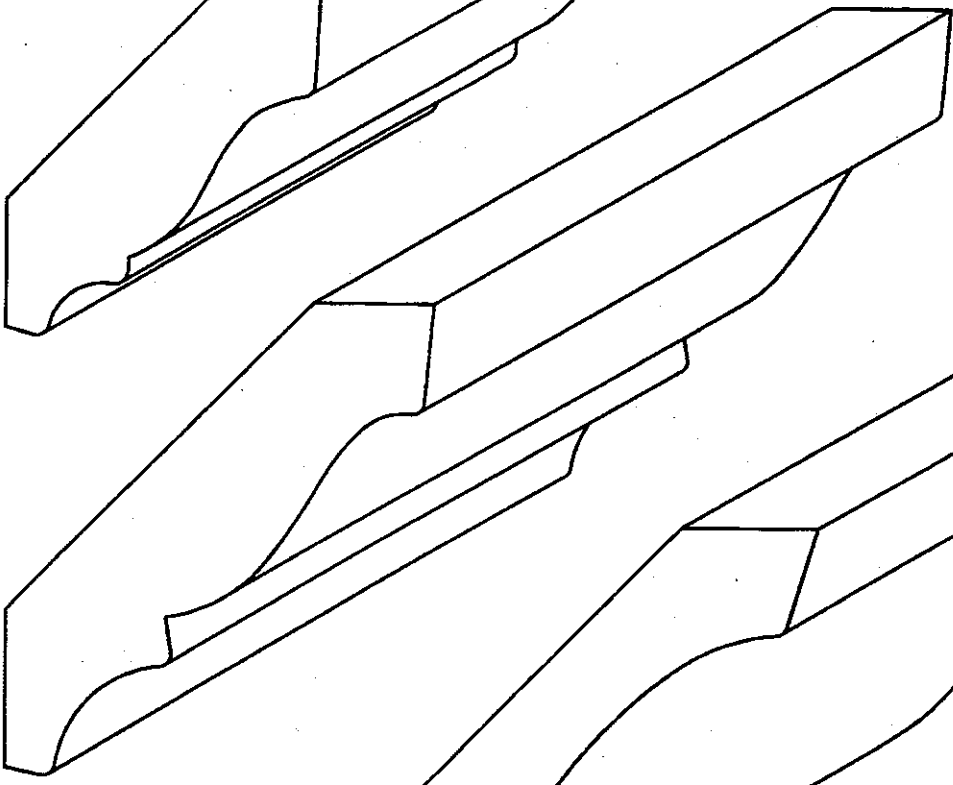

CM47
3/4 X 3-1/4

A technical drawing of a crown molding profile, labeled CM47. It features a more pronounced, curved profile on its front face compared to CM46. The drawing is shown in a perspective view, illustrating the depth and curvature of the molding.

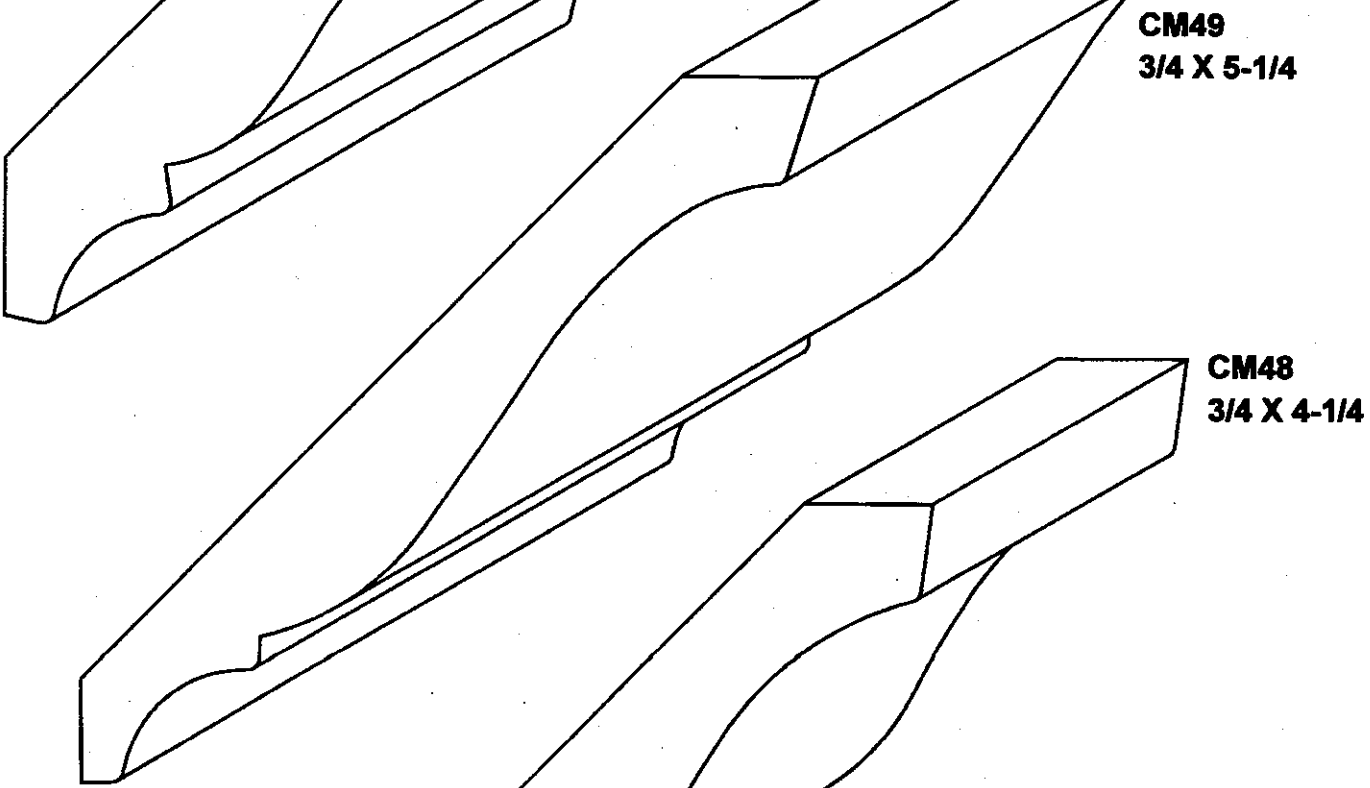

CM49
3/4 X 5-1/4

A technical drawing of a crown molding profile, labeled CM49. This profile has a very deep and wide, curved front face, giving it a more dramatic and ornate appearance. The drawing is shown in a perspective view, emphasizing its large scale and complex curvature.

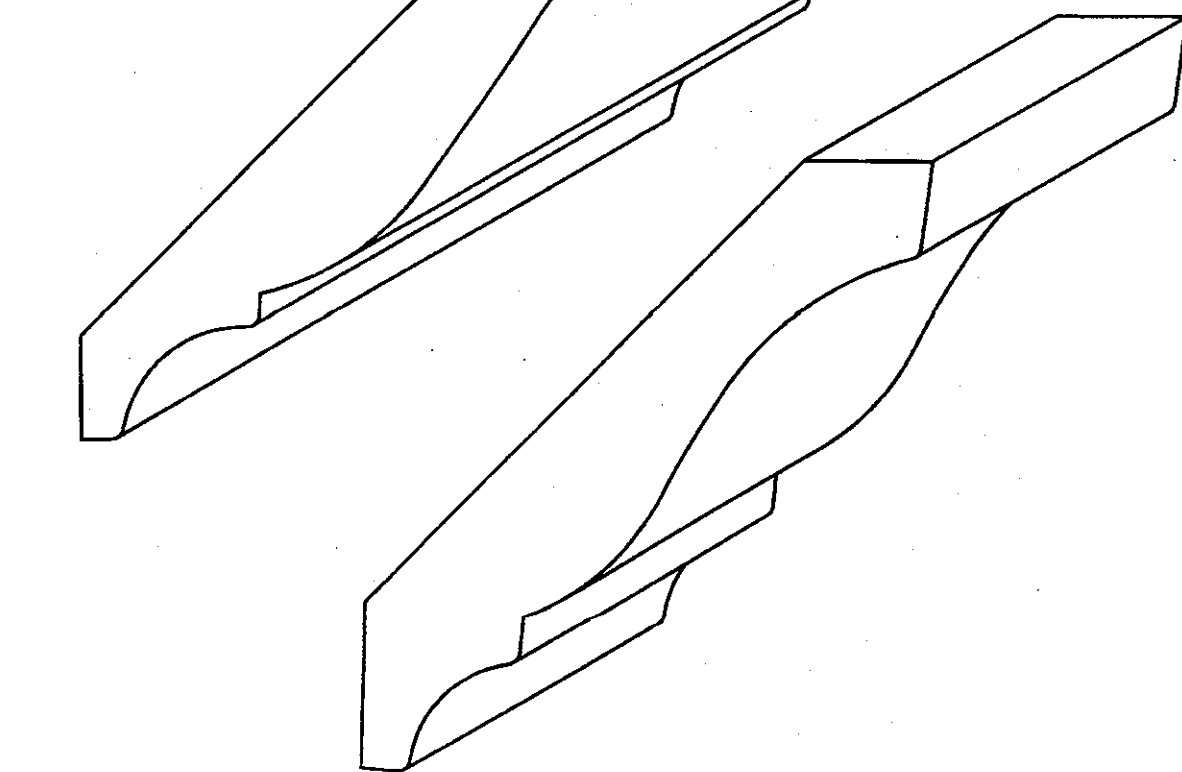

CM48
3/4 X 4-1/4

A technical drawing of a crown molding profile, labeled CM48. It has a deep, curved front face that is narrower than CM49 but wider than CM47. The drawing is shown in a perspective view, showing the detailed profile of the molding.

Crowns

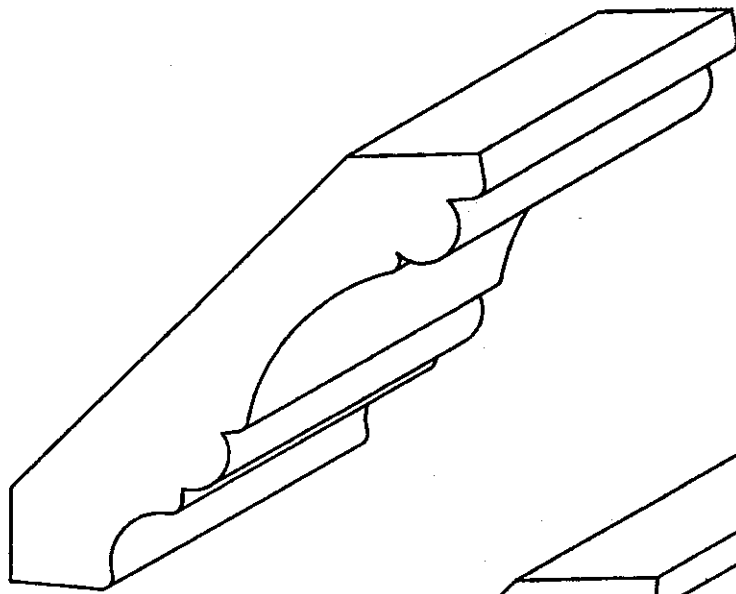

CM47B
3/4 x 3-1/4

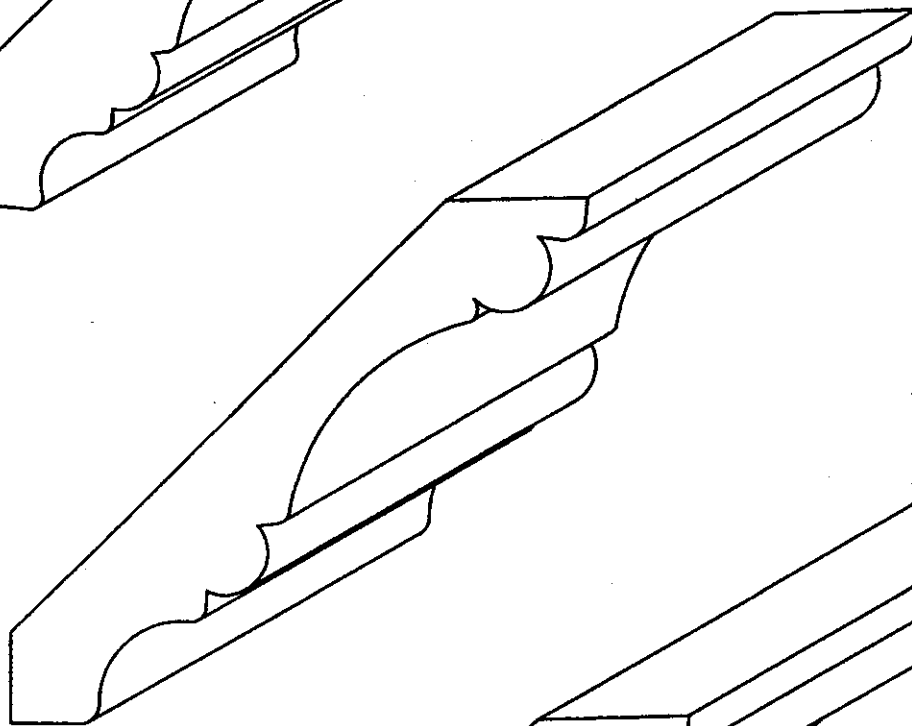

CM48B
3/4 X 4-1/4

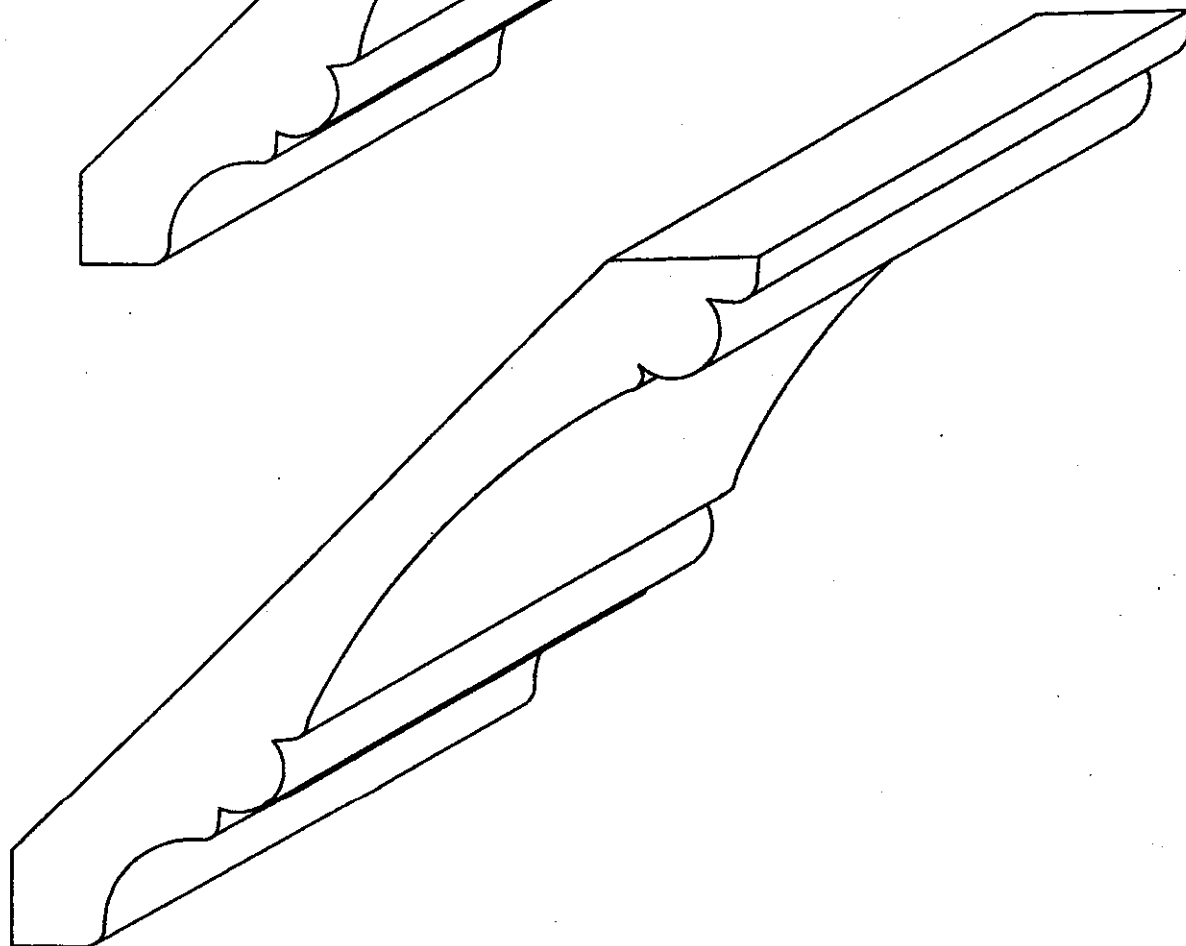

CM49B
3/4 X 5-1/4

Crowns

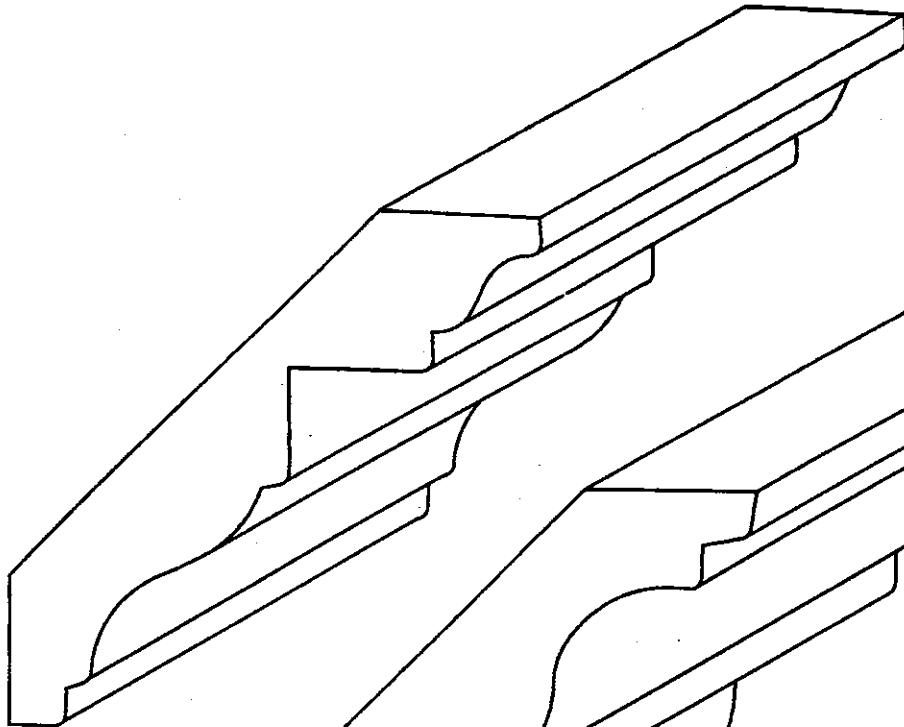

CM334D
3/4 X 3-3/4

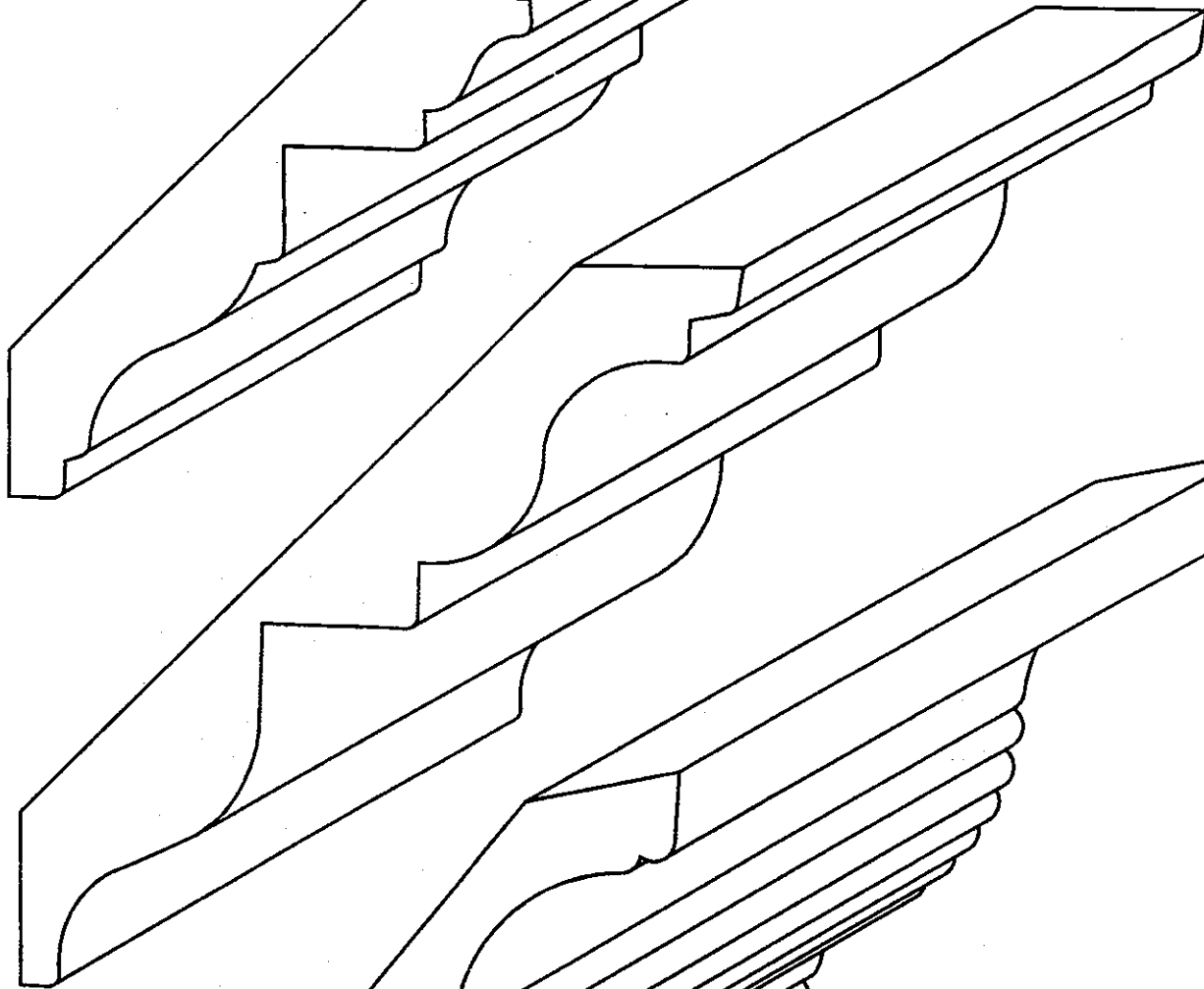

CM49D
3/4 X 5-1/4

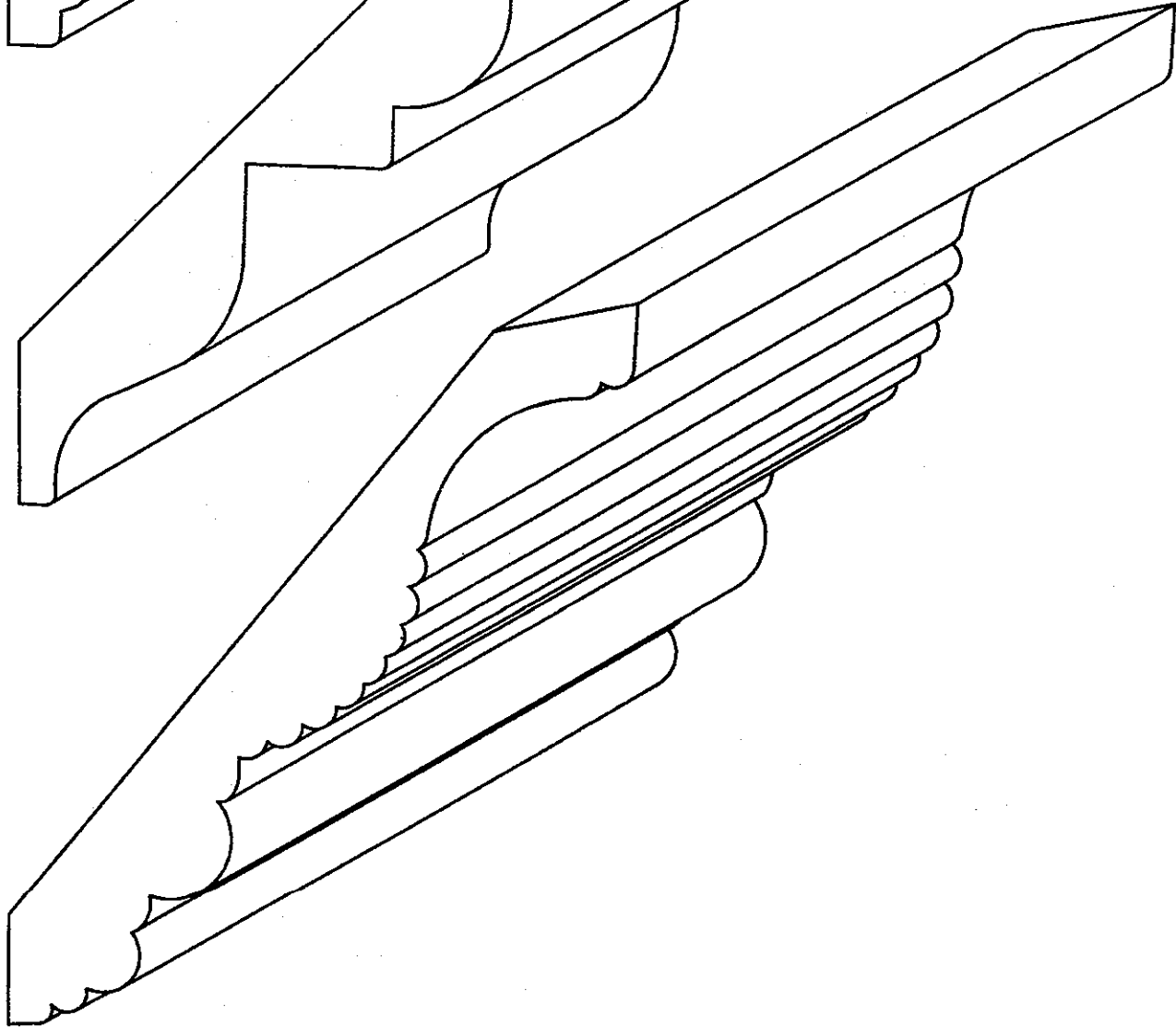

CM49R
3/4 X 5-1/4

Bases

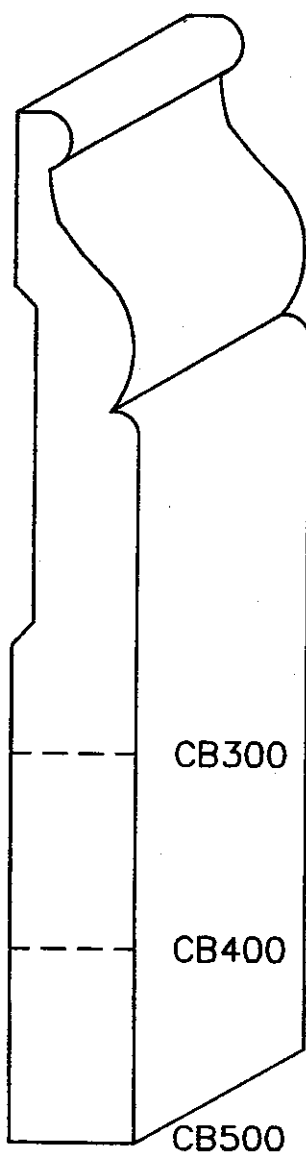

CB700
5/8 X 7-1/4
(not shown)

CB500
5/8 X 5-1/4

CB400
5/8 X 4-1/4

CB300
5/8 X 3-1/4

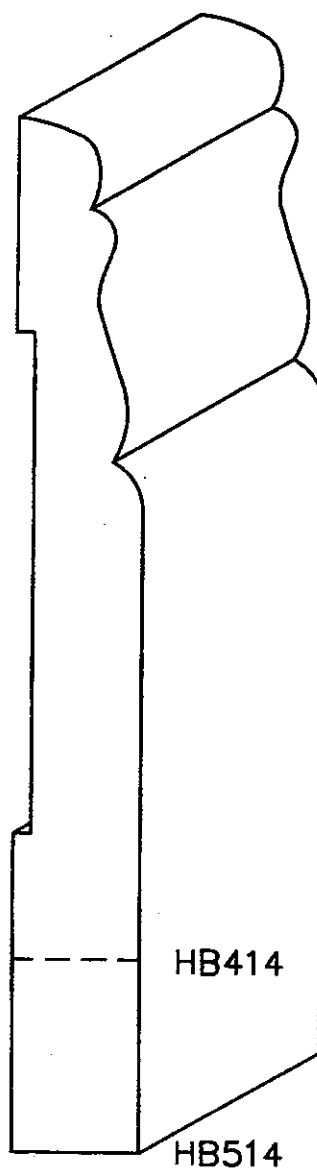

HB514
5/8 X 5-1/4

HB414
5/8 X 4-1/4

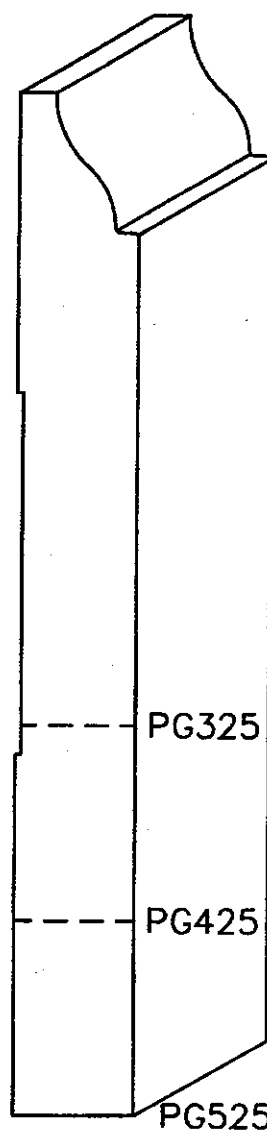

***PG525**
5/8 X 5-1/4

PG425
5/8 X 4-1/4

PG325
5/8 X 3-1/4

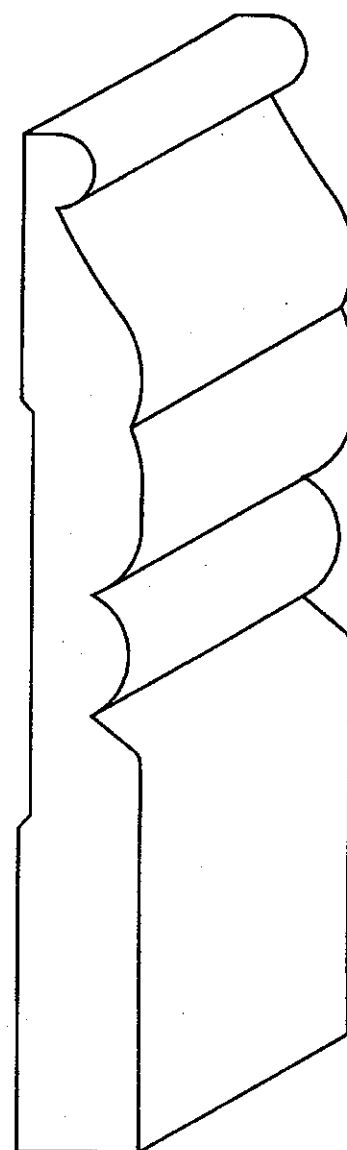

KB525
5/8 X 5-1/4

Chair Rails

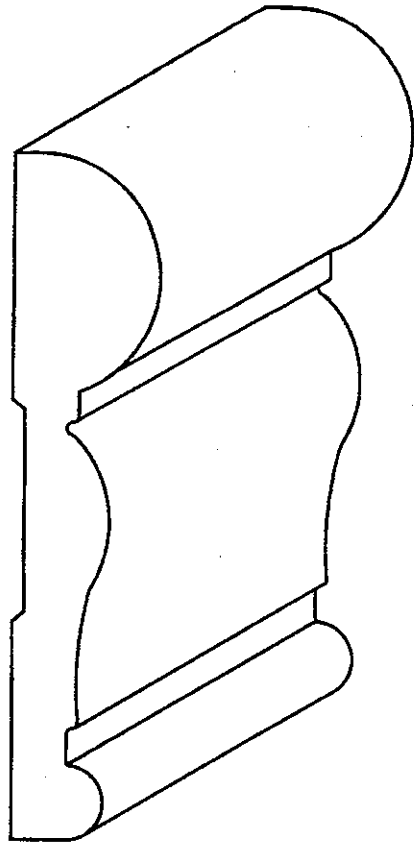

CR312
3/4 X 3-1/2

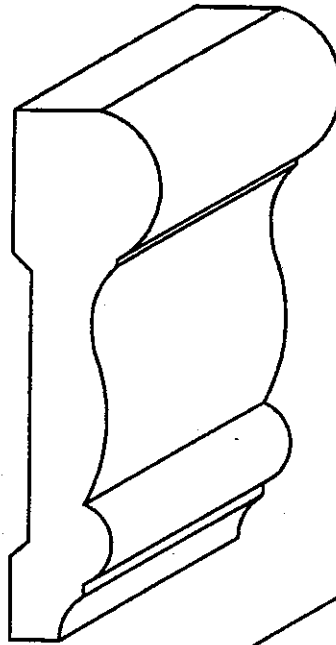

CR234
3/4 X 2-3/4

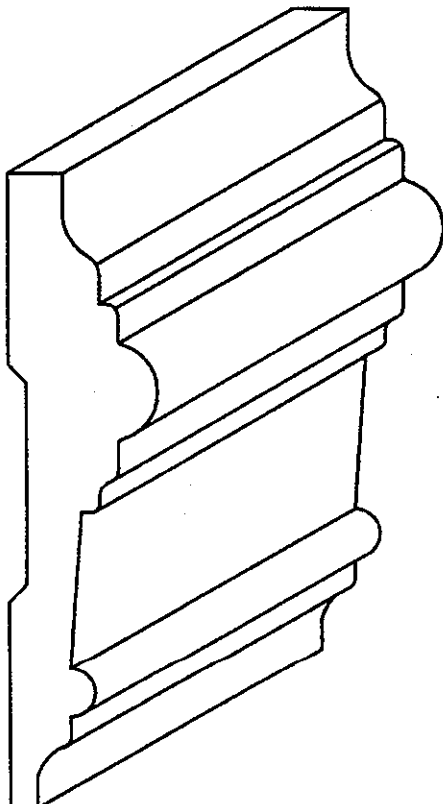

CR314
3/4 X 3-1/4

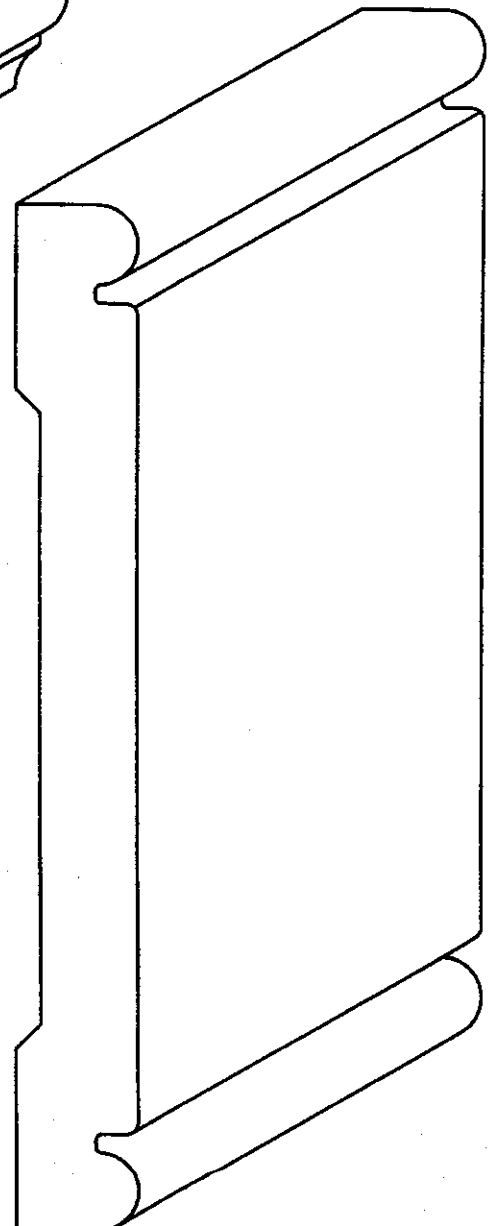

***CRB525**
3/4 X 5-1/4

*Special Run

Panel Molds

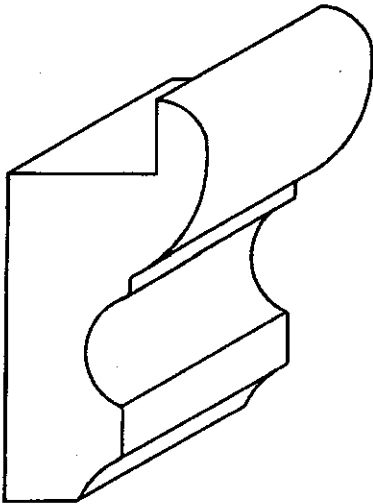

PM200-34
1-1/16 X 2
W/ 3/4" RABID

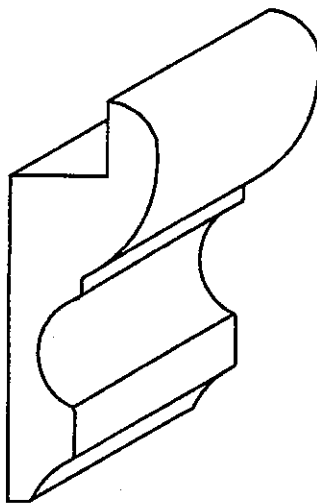

PM200-12
3/4 X 2
W/ 1/2" RABID

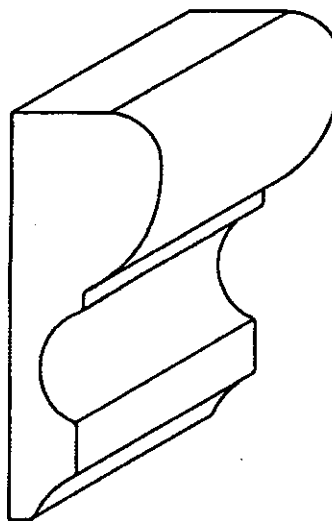

PM200
3/4 X 2

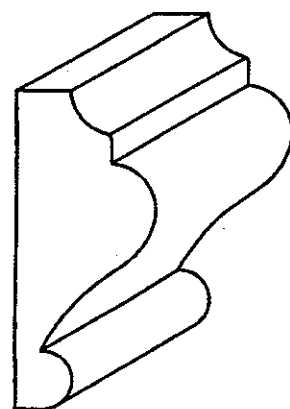

PM150
3/4 X 1-9/16

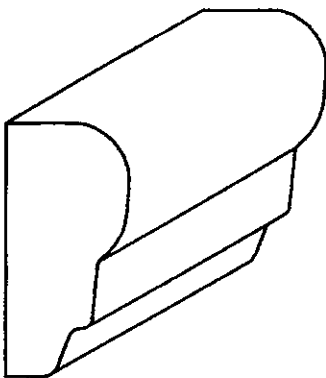

BM125
5/8 X 1-1/4

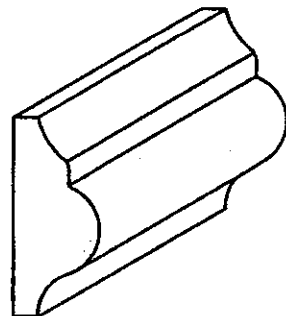

BM100
1/2 X 1

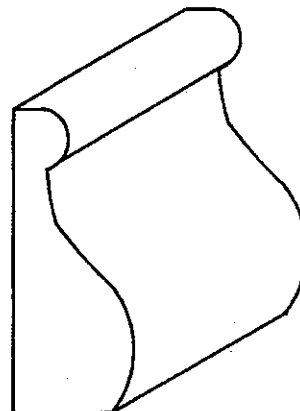

BC138
5/8 X 1-3/8

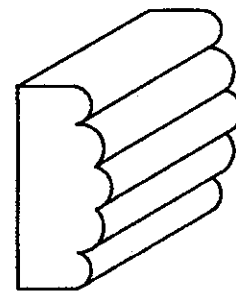

RM100
7/16 X 1

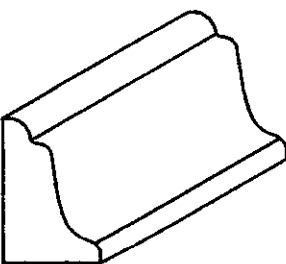

#95
1/2 X 3/4

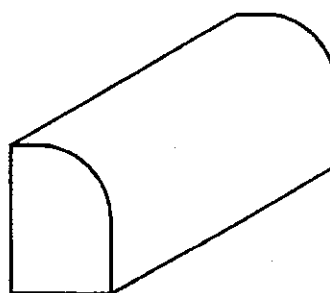

#127
1/2 X 3/4

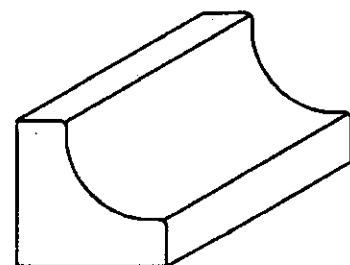

#93
3/4 X 3/4

Window Stools/Vee Grooves

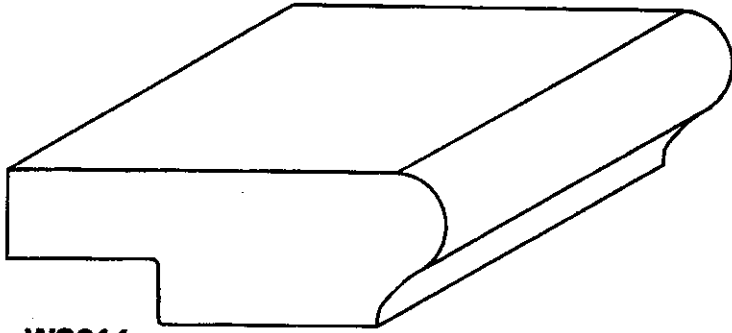

WS214
3/4 X 2-1/4

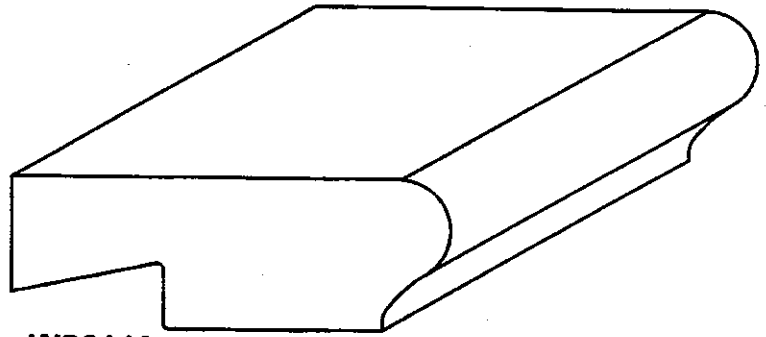

WS214A
3/4 X 2-1/4

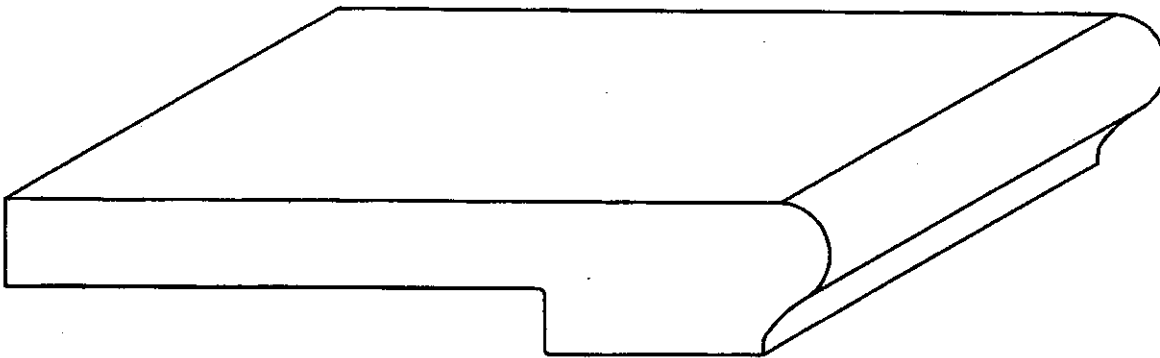

WS414
3/4 X 4-1/4

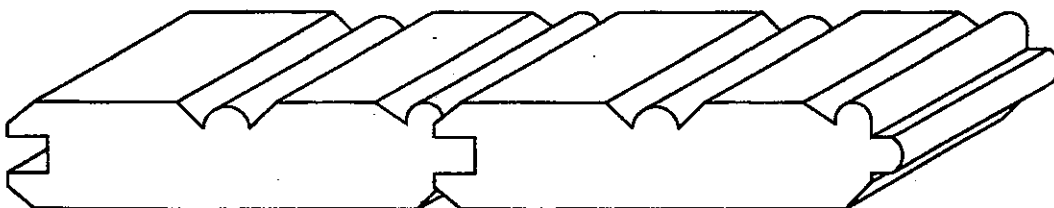

VG325 3/4 X 3-1/4
***VG425 3/4 X 4-1/4**
***VG525 3/4 X 5-1/4**

Not To Scale

Jambs

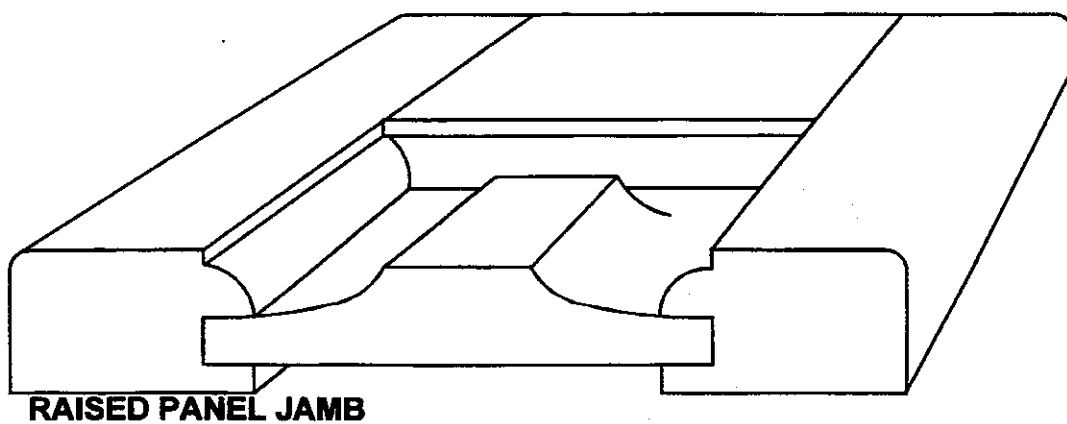
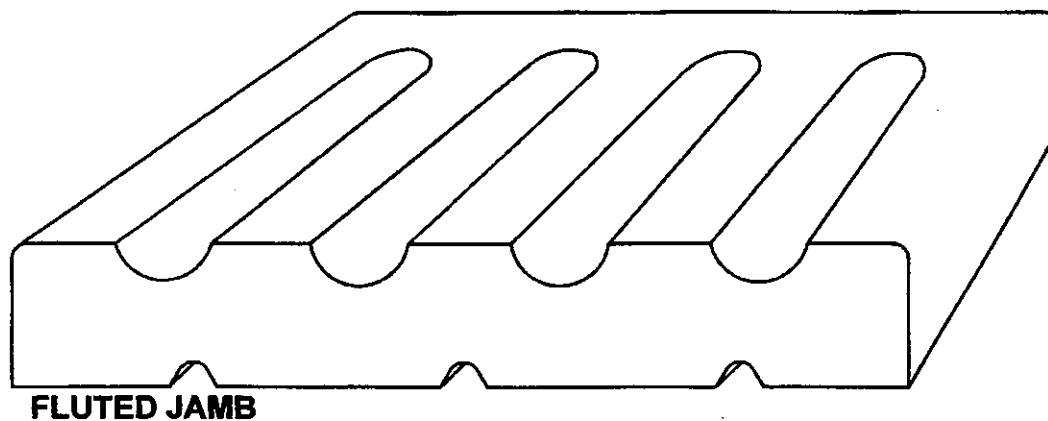
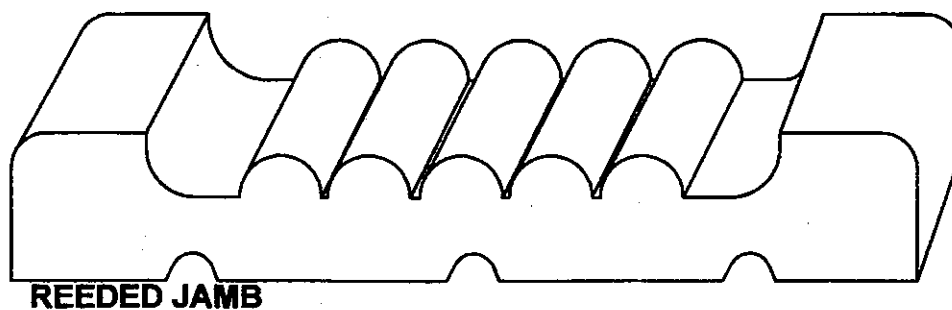
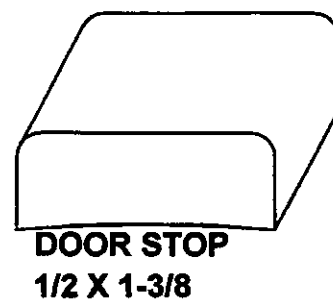
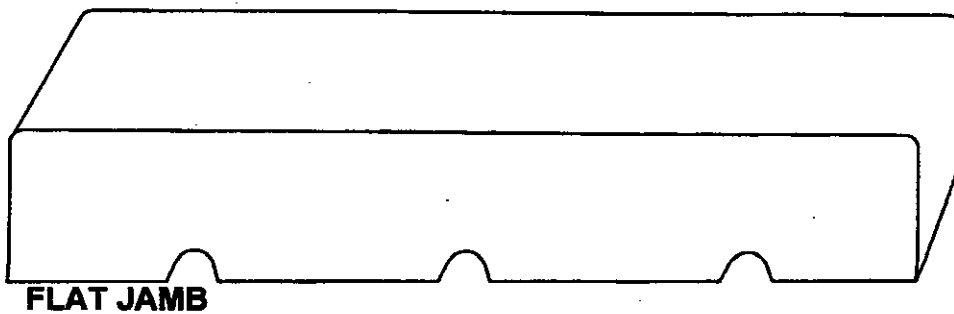

S4S Material

NOT TO SCALE

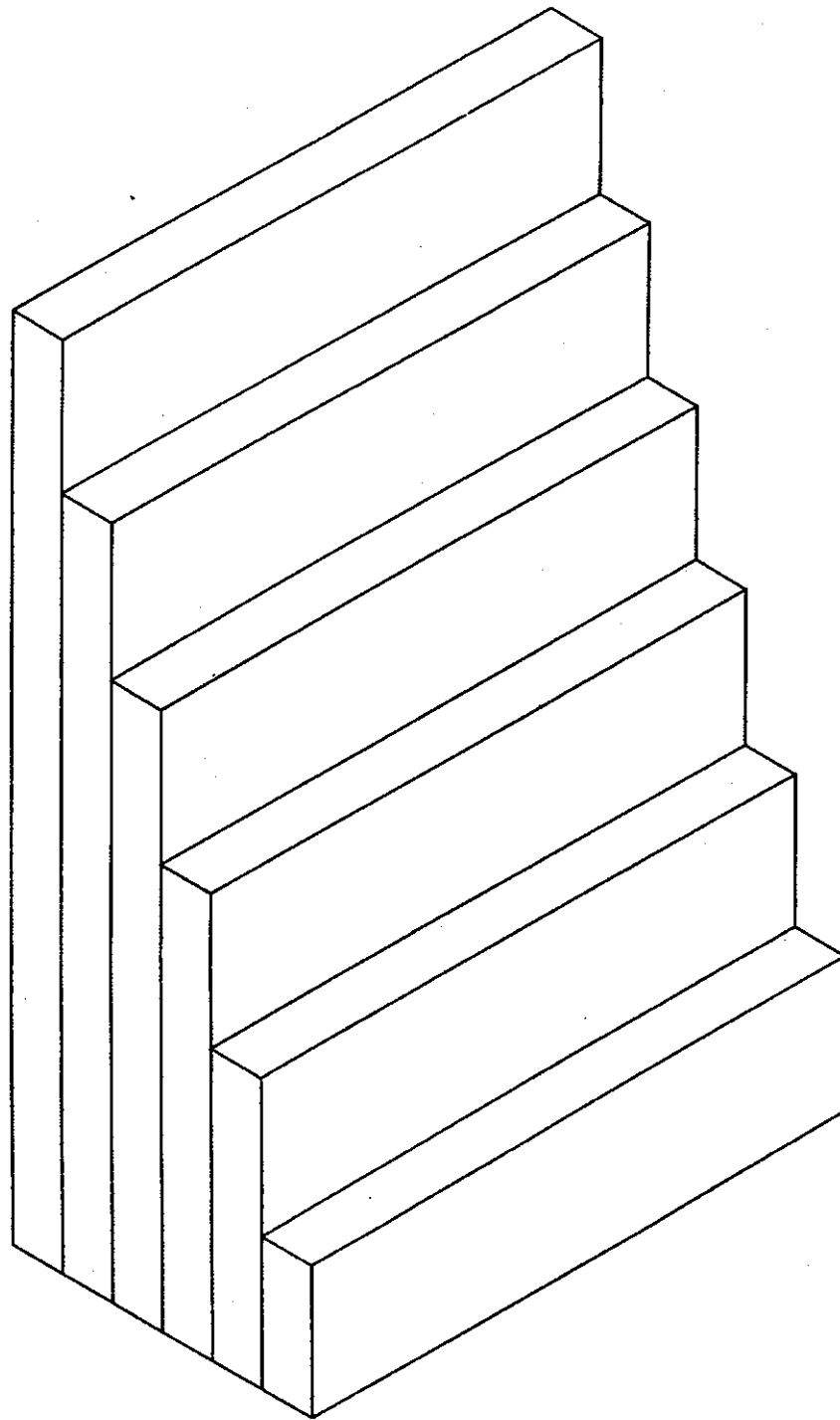

4/4X12
3/4 X 11-1/4

4/4X10
3/4 X 9-1/4

4/4X8
3/4 X 7-1/4

4/4X6
3/4 X 5-1/4

4/4X4
3/4 X 3-1/2

4/4X2
3/4 X 2

5/4, 6/4 and 8/4 Material Available

Trim Blocks

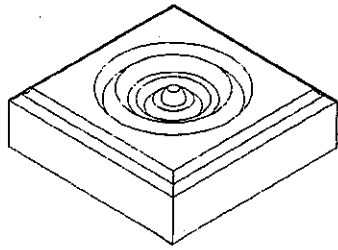

ROSETTE

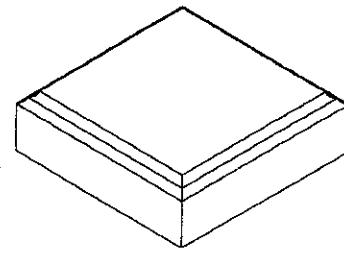

PLAIN CASING BLOCK



KEYSTONE

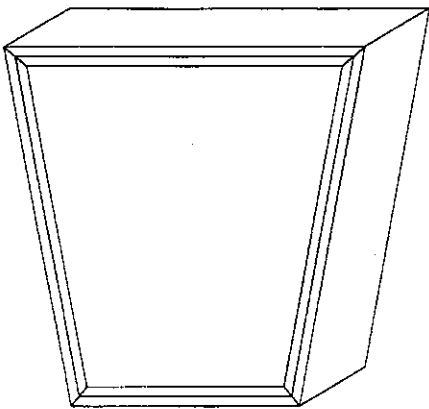

PLAIN

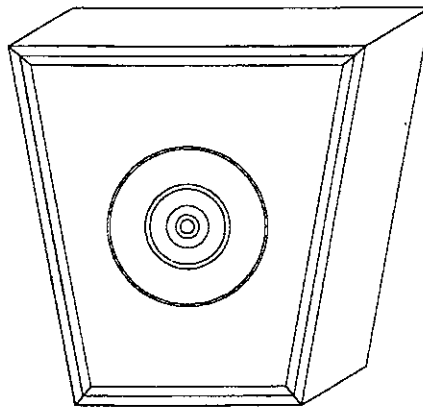

W/CIRCLE

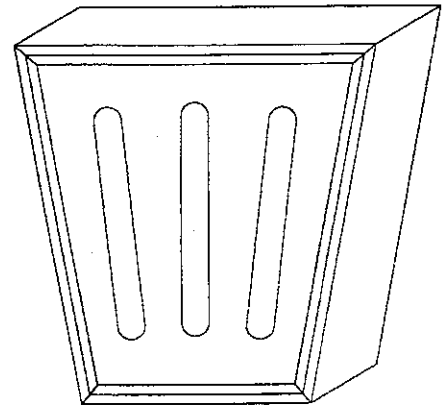

FLUTED

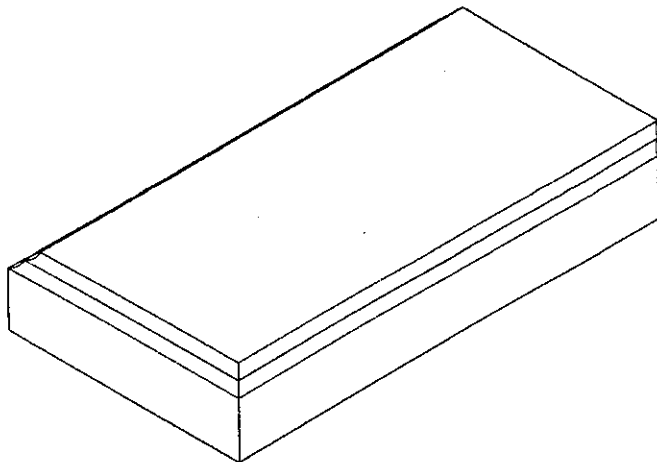

PLINTH BLOCK

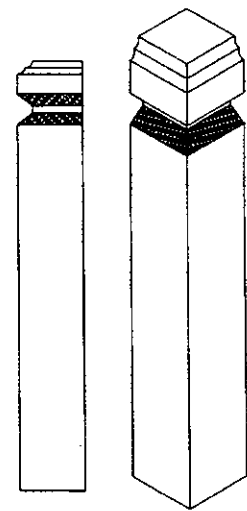

BASE BLOCK

ALL BLOCKS RANGE IN MANY SIZES TO SUIT YOUR INDIVIDUAL NEEDS.

Crown Blocks

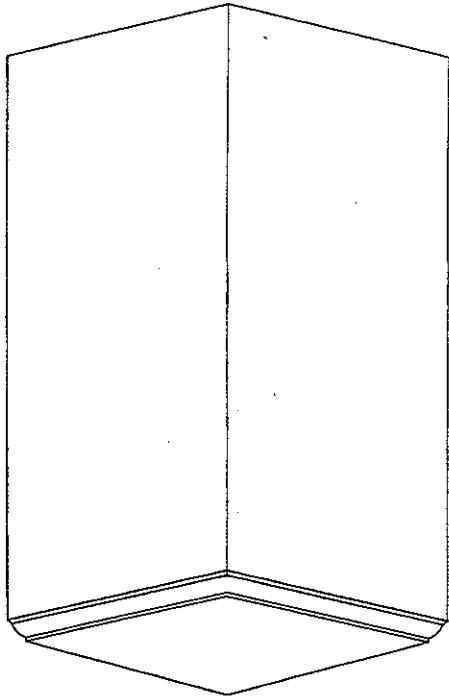

CROWN BLOCK

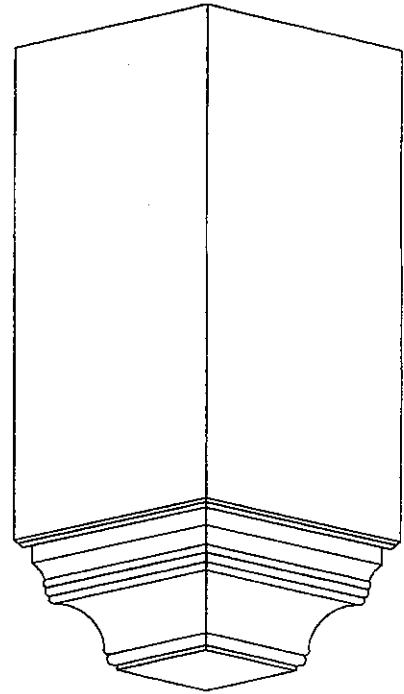

***CROWN BLOCK
W/ CROWN ASSEMBLY**

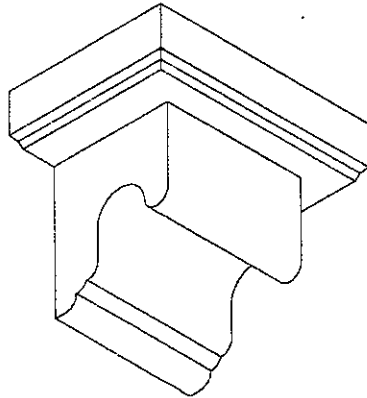

***ATLANTA DENTIL**

CUMBERLAND'S DOORS OF PRIDE

Cumberland Millwork & Supply carries a complete line of interior doors. Flush, assorted masonite, french lite doors and more. But, our doors of pride are our solid hardwood panel doors. Poplar and Red Oak doors are readily available with other species available with adequate lead times. Six Panel Poplar doors with full 1-3/16" or 3/4" panels are offered as stock. These doors are made of solid materials. No veneers or wood product cores are used. Dowel construction assures added strength. All for about the same price of Pine. Many panel designs are available with adequate lead times. See your local sales representative for more details. Our doors help us in *Striving to be the Best in Interior Millwork.*

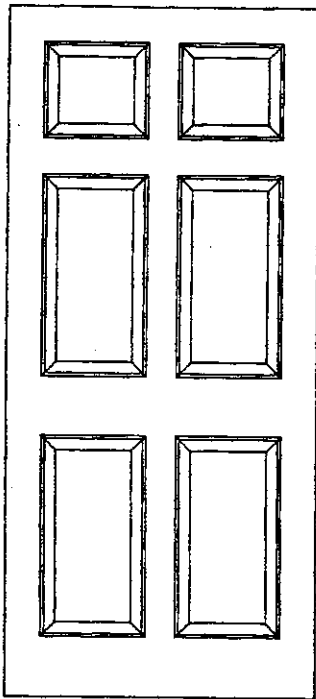

Six Panel
1-3/8" or 3/4"

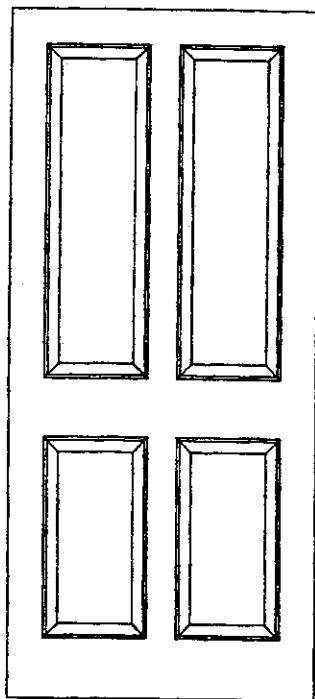

Four Panel
1-3/8" or 3/4"

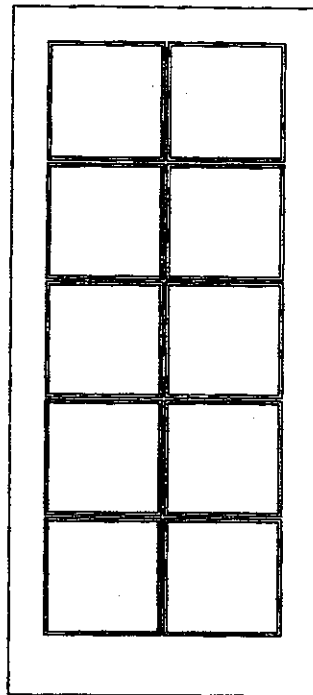

French Lite Door

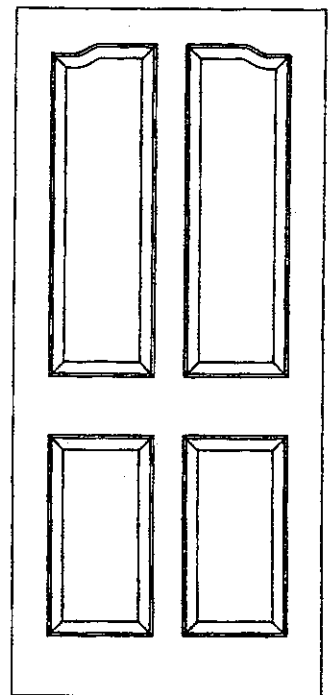

Four Panel
Provincial

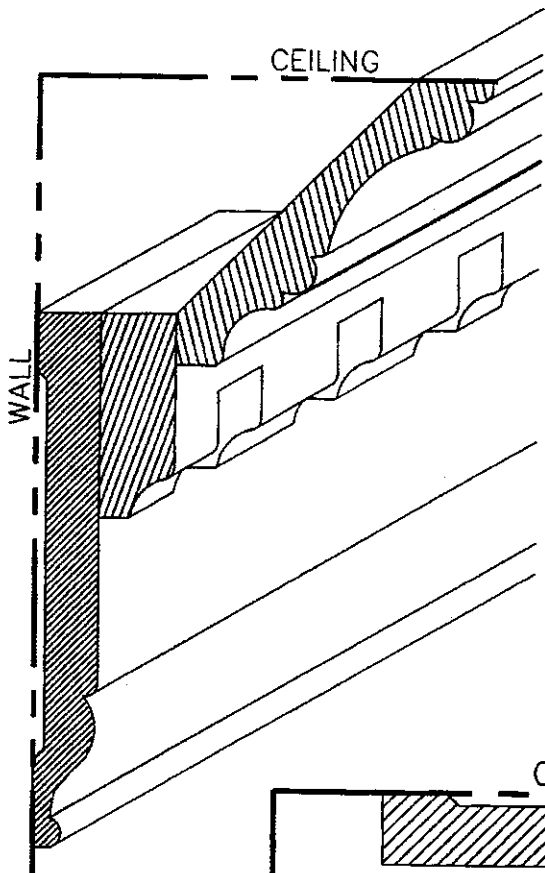

3 PIECE CROWN MOLDING

**CM48B
DD
CB400**

**CROWN
DENTIL
BASE**

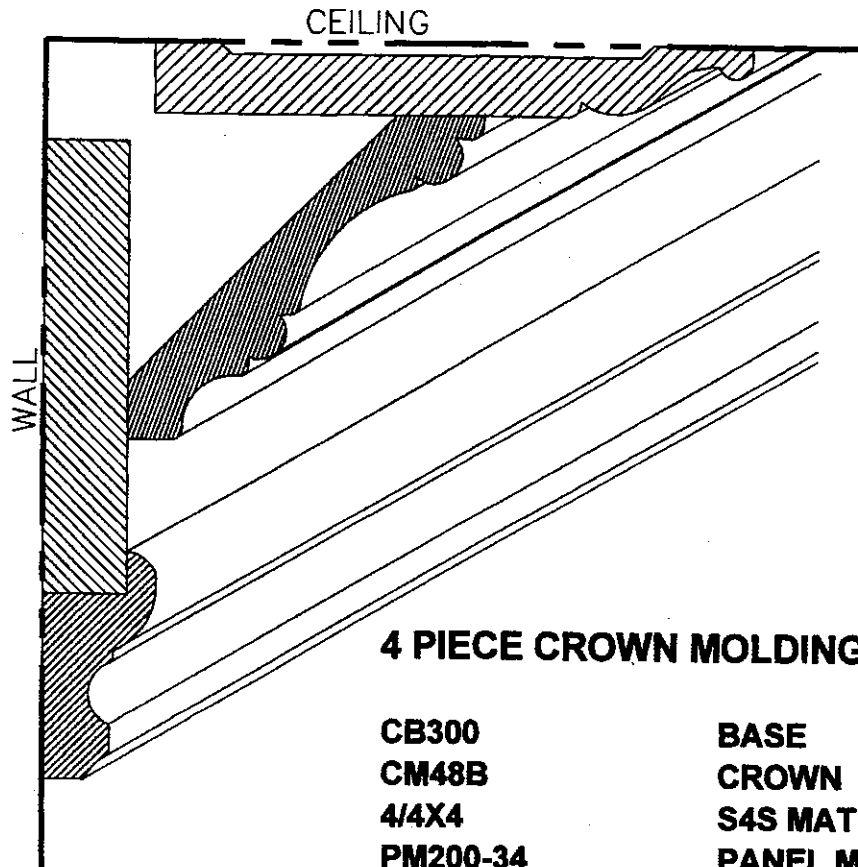

4 PIECE CROWN MOLDING

**CB300
CM48B
4/4X4
PM200-34**

**BASE
CROWN
S4S MATERIAL
PANEL MOLD**

Many other multi-piece crown assemblies available.

Custom Casings

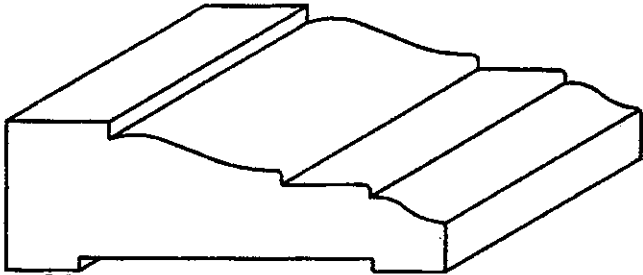

***C366**
3/4 X 2-1/4

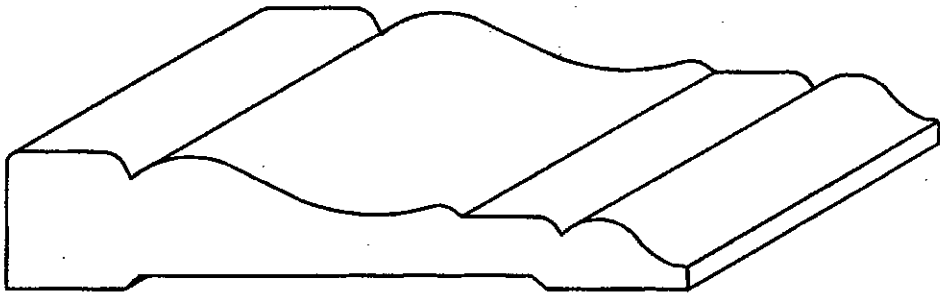

***C353**
3/4 X 3-1/2

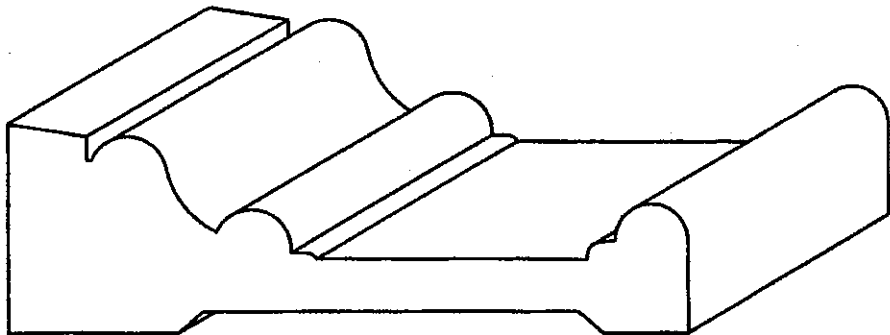

***KN535**
1 X 3-1/2

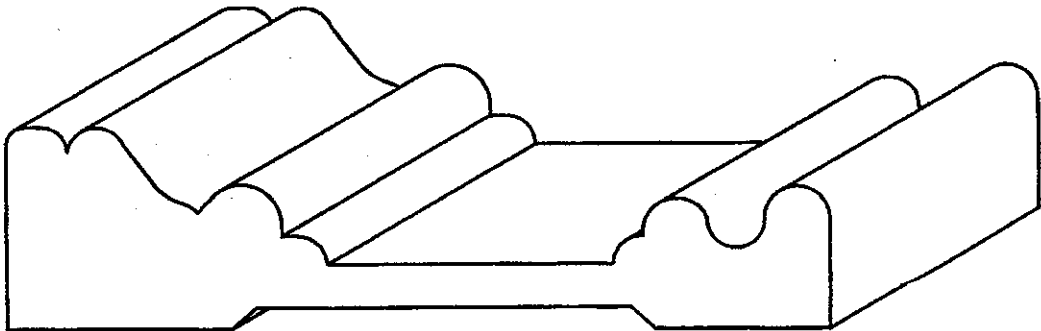

***KN540**
1-1/16 X 4-1/4

Custom Casings

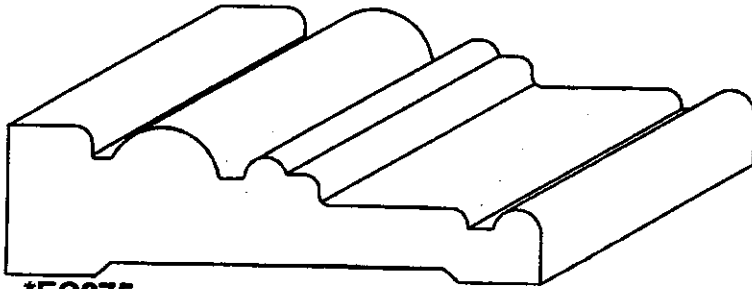

***EC275**
3/4 X 2-3/4

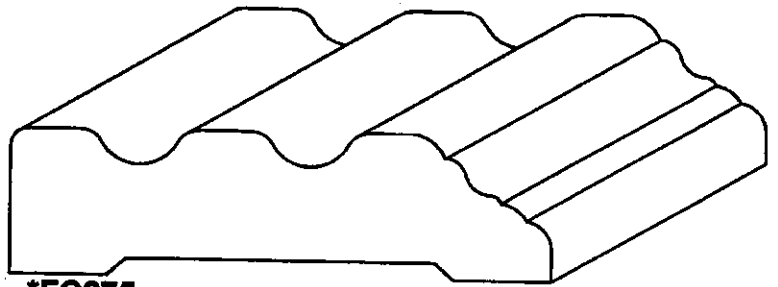

***FC275**
3/4 X 2-3/4

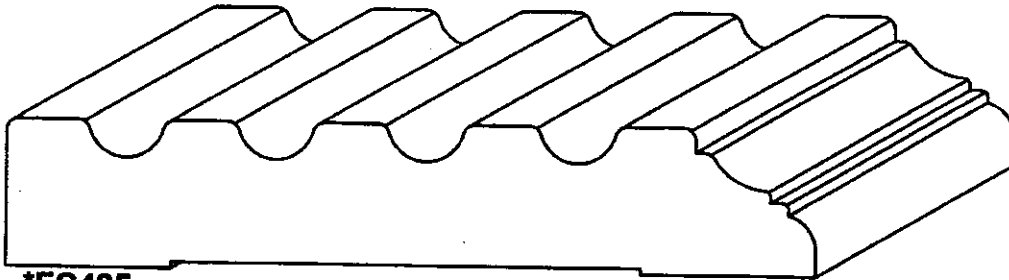

***FC425**
3/4 X 4-1/4

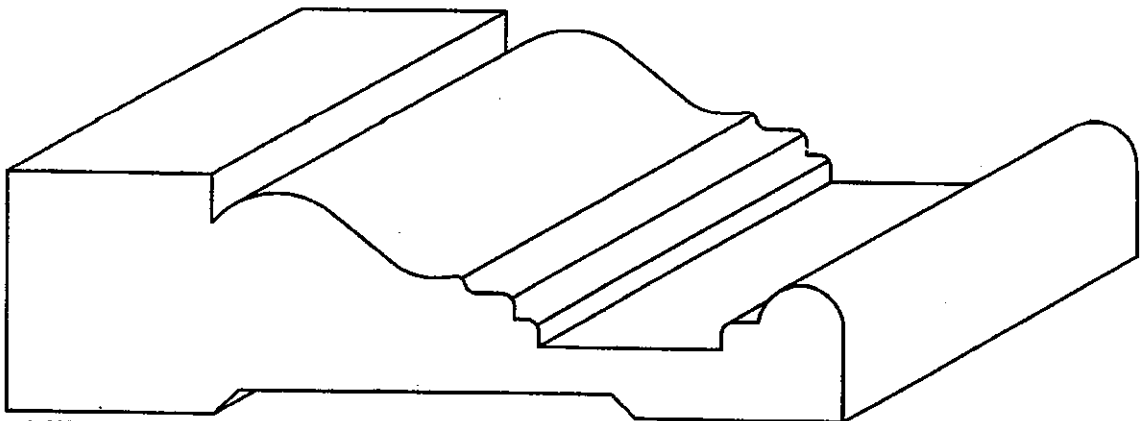

***JF425**
1-1/16 X 4-1/4

Custom Casings

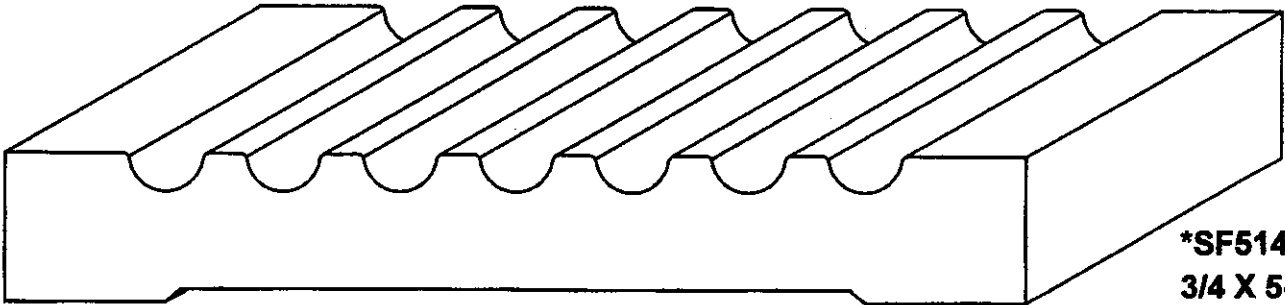

***SF514**
3/4 X 5-1/4

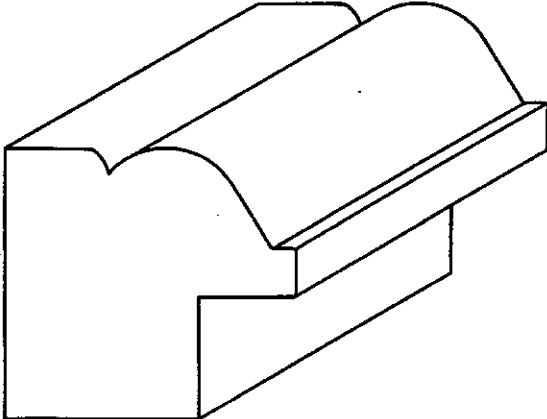

***BB122**
1-1/2 X 1-1/2

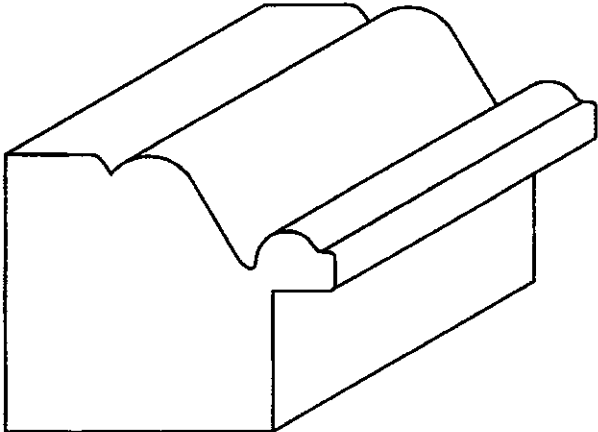

***BB158**
1-3/8 X 1-5/8

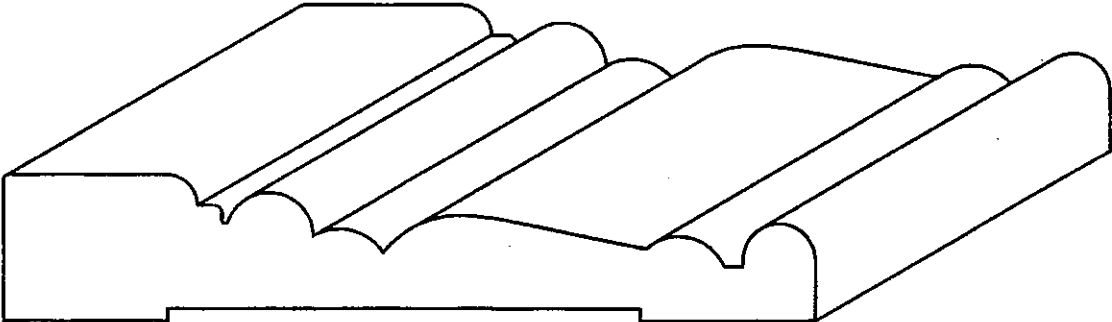

***AM425**
3/4 X 4-1/4

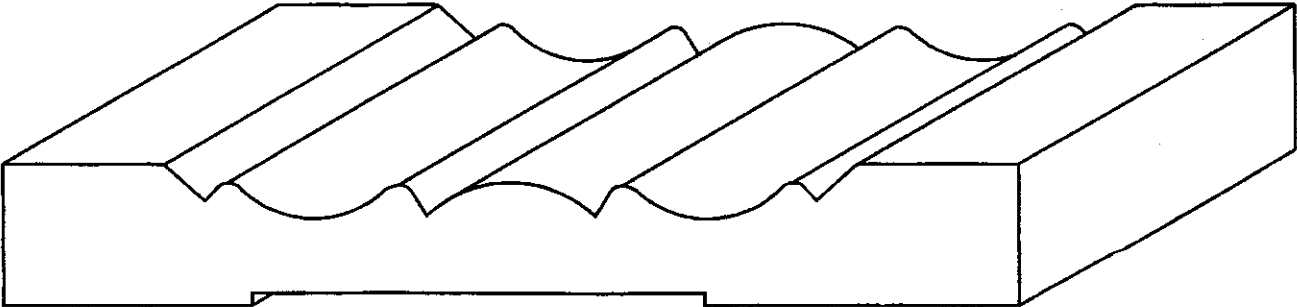

***CC550**
3/4 X 5-1/4

Custom Casings

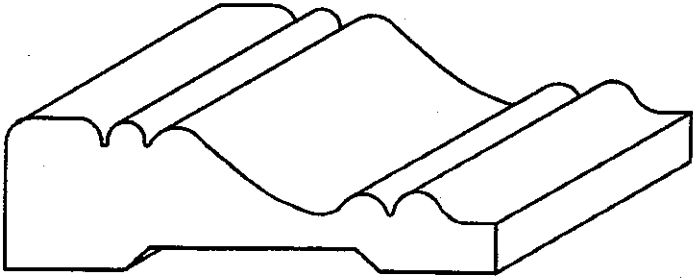

***GW250**
3/4 X 2-1/2

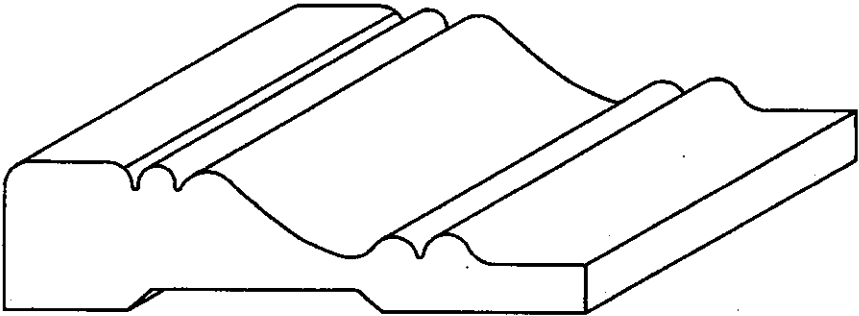

***GW300**
3/4 X 3

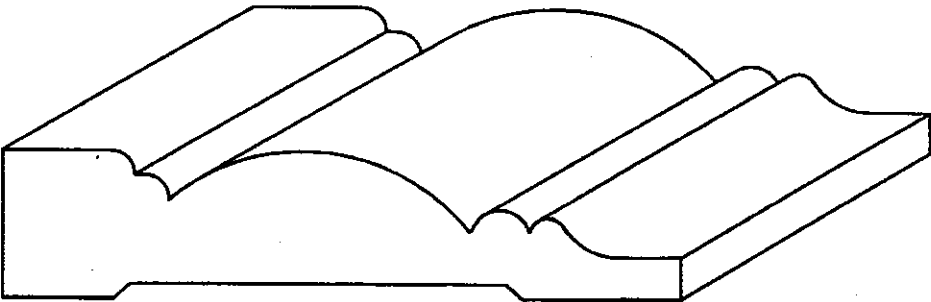

***PC350**
3/4 X 3-1/2

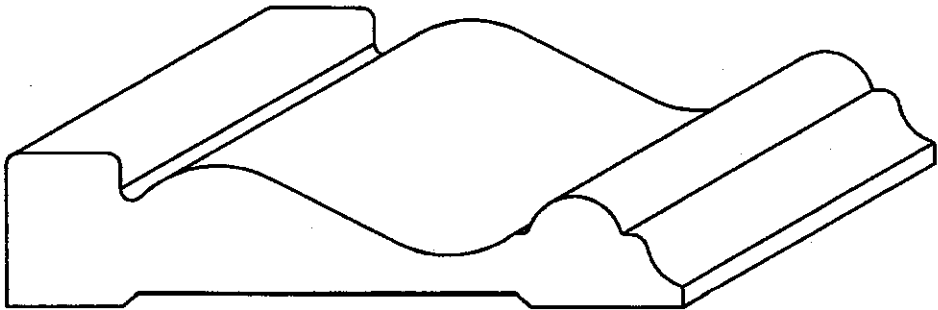

***LL350**
3/4 X 3-1/2

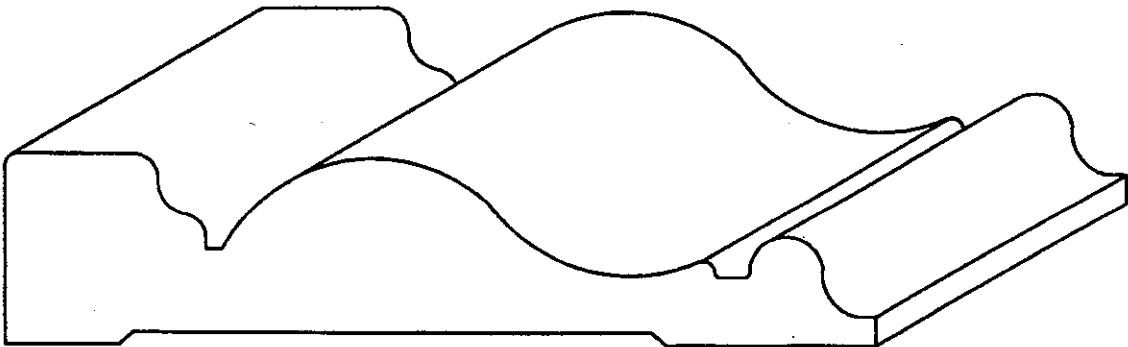

***LL545**
1 X 4-1/2

Custom Casings

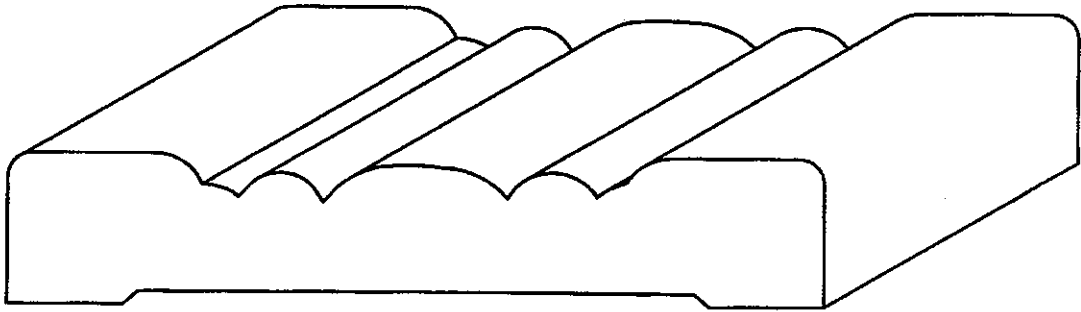

***PS425**
3/4 X 4-1/4

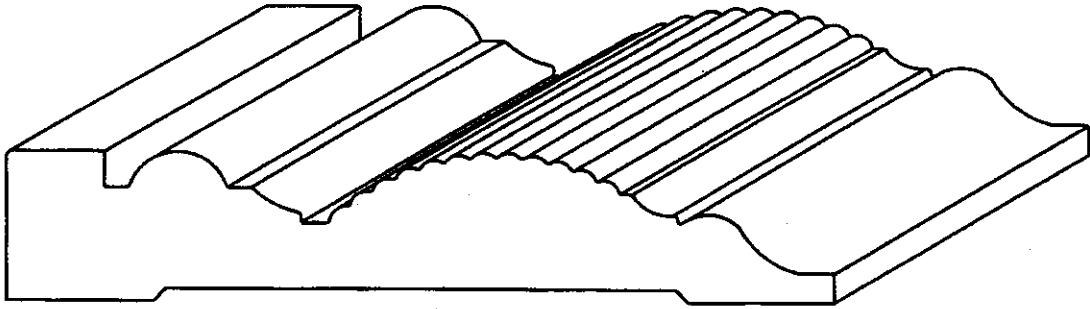

***RC425**
3/4 X 4-1/4

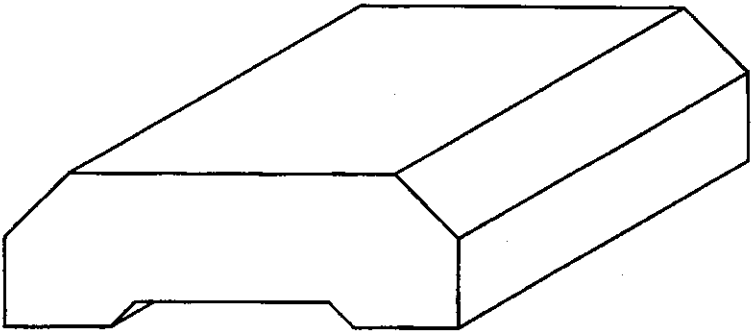

***CT225**
3/4 X 2-1/4

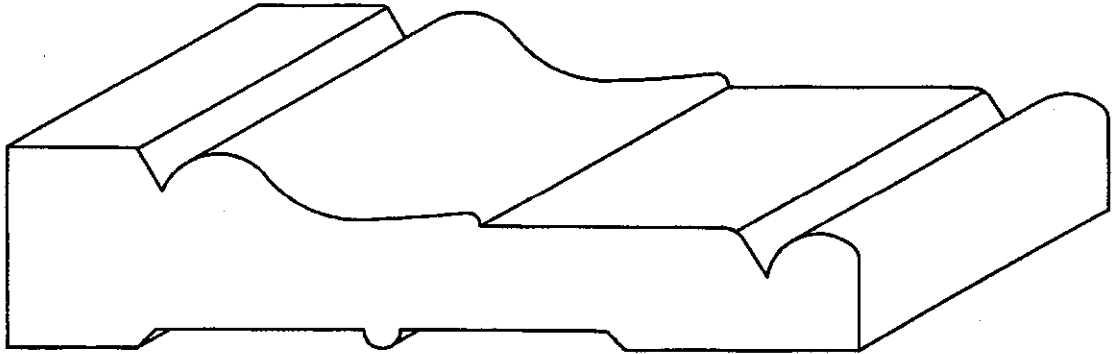

***C425**
1 X 4-1/4

Custom Casings

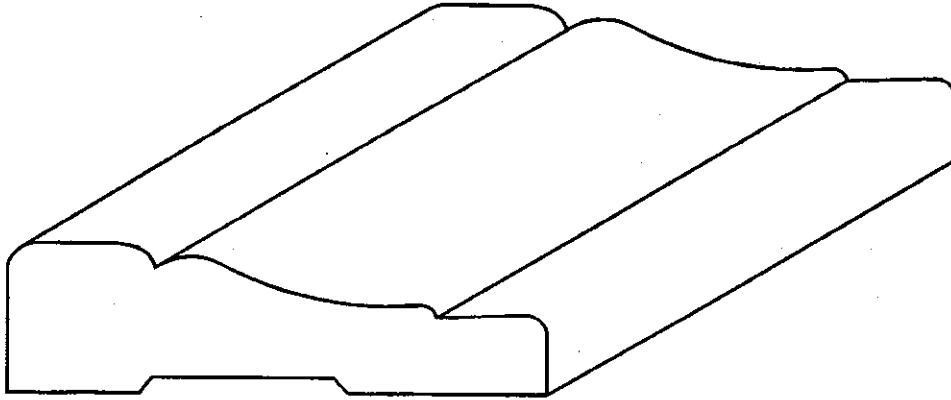

***C376**
3/4 X 2-3/4

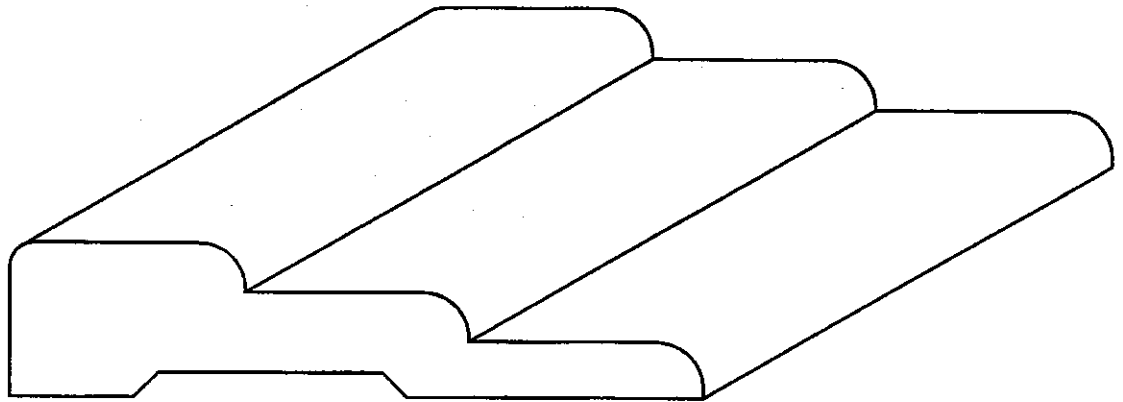

***TE350**
3/4 X 3-1/2

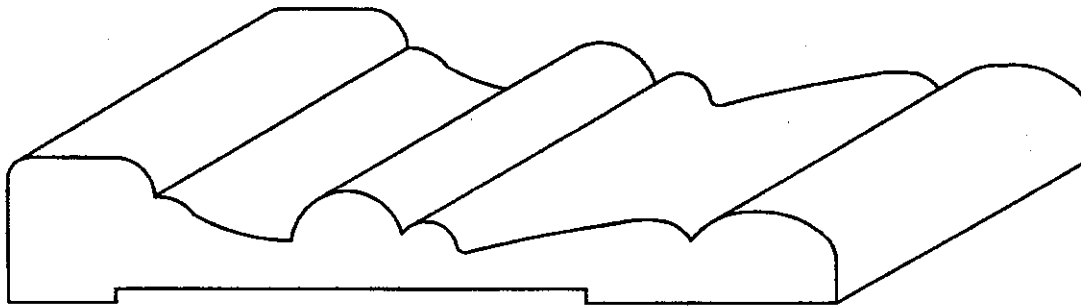

***DB425**
3/4 X 4-1/4

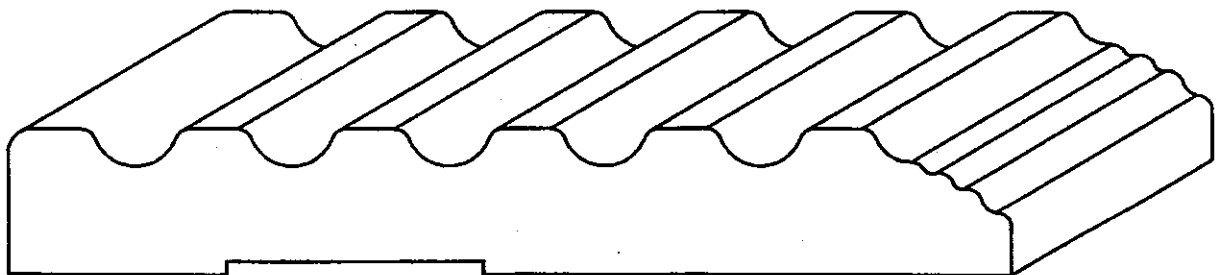

***FC525**
3/4 X 5-1/8

Custom Bases

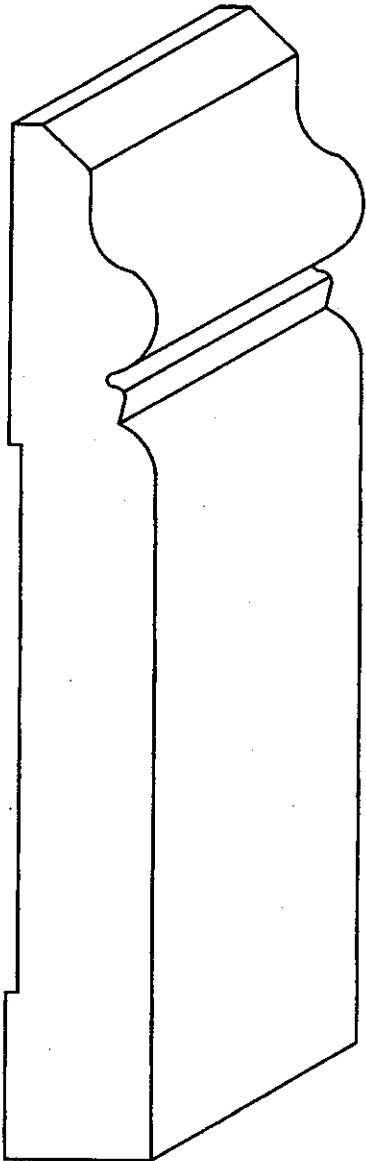

***BJ514**
3/4 X 5-1/4

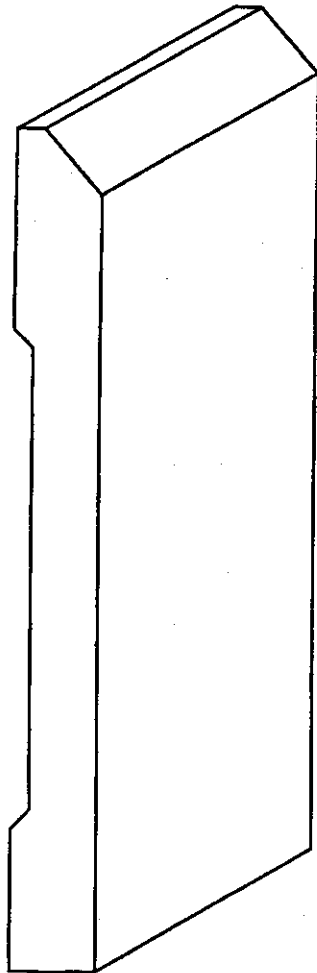

***CT525**
7/16 X 5-1/4

***CT425**
7/16 X 4-1/4

***CT325**
7/16 X 3-1/4

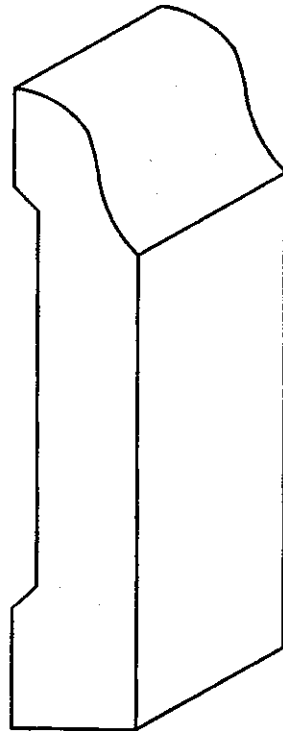

***OG514**
5/8 X 5-1/4

***OG414**
5/8 X 4-1/4

***OG314**
5/8 X 3-1/4

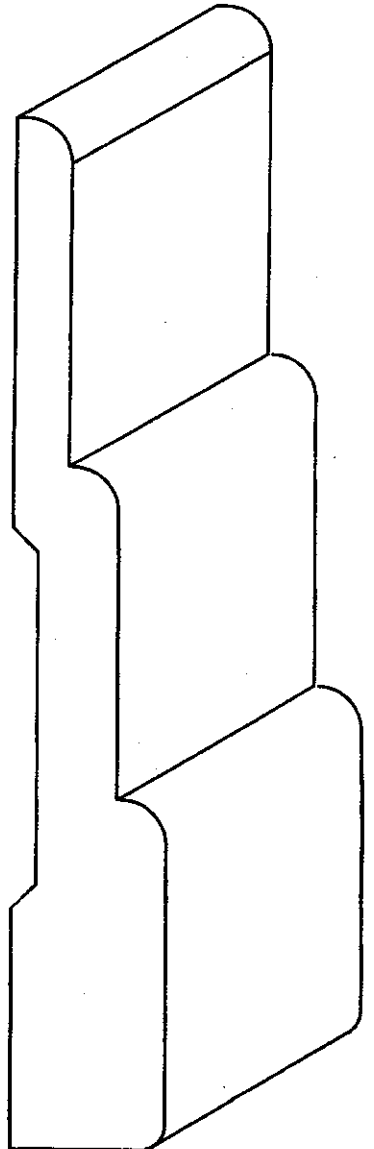

***TE525**
3/4 X 5-1/4

Custom Crowns

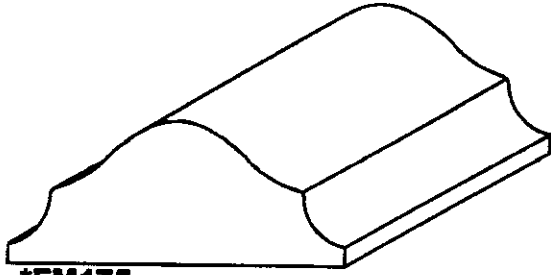

***FM175**
3/4 X 1-3/4

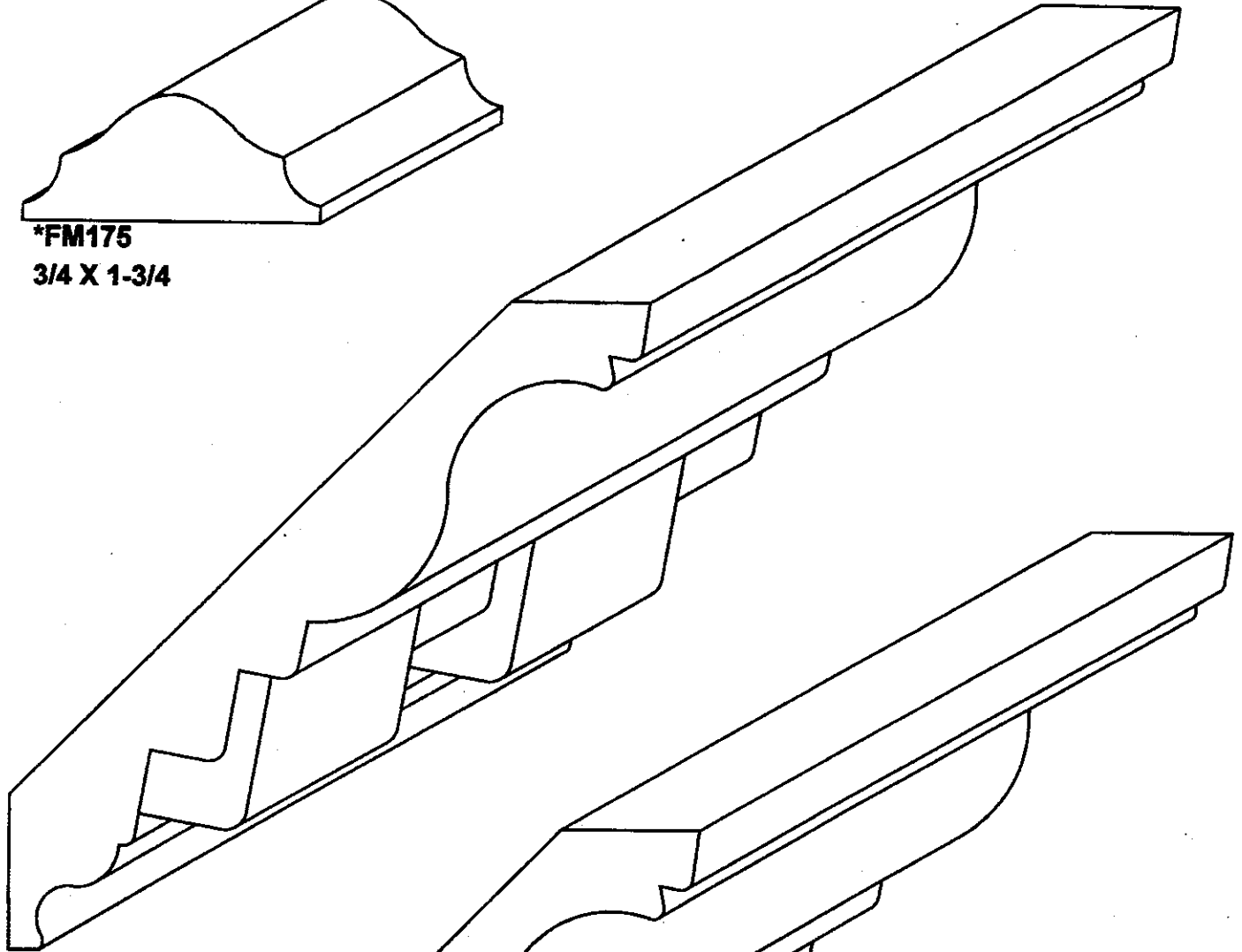

***CM49Z**
3/4 X 5-1/4

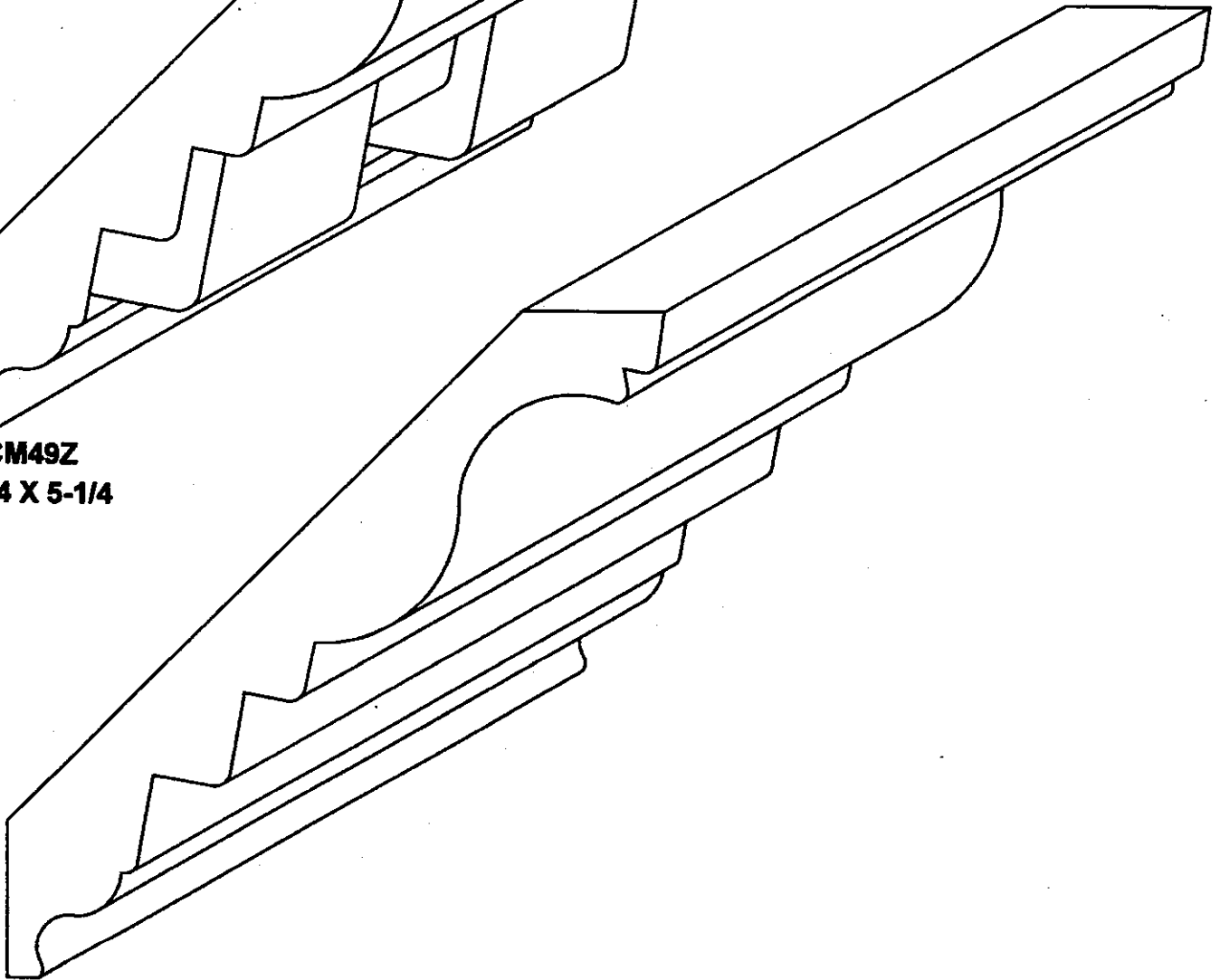

***CM49N**
3/4 X 5-1/4

Custom Crowns

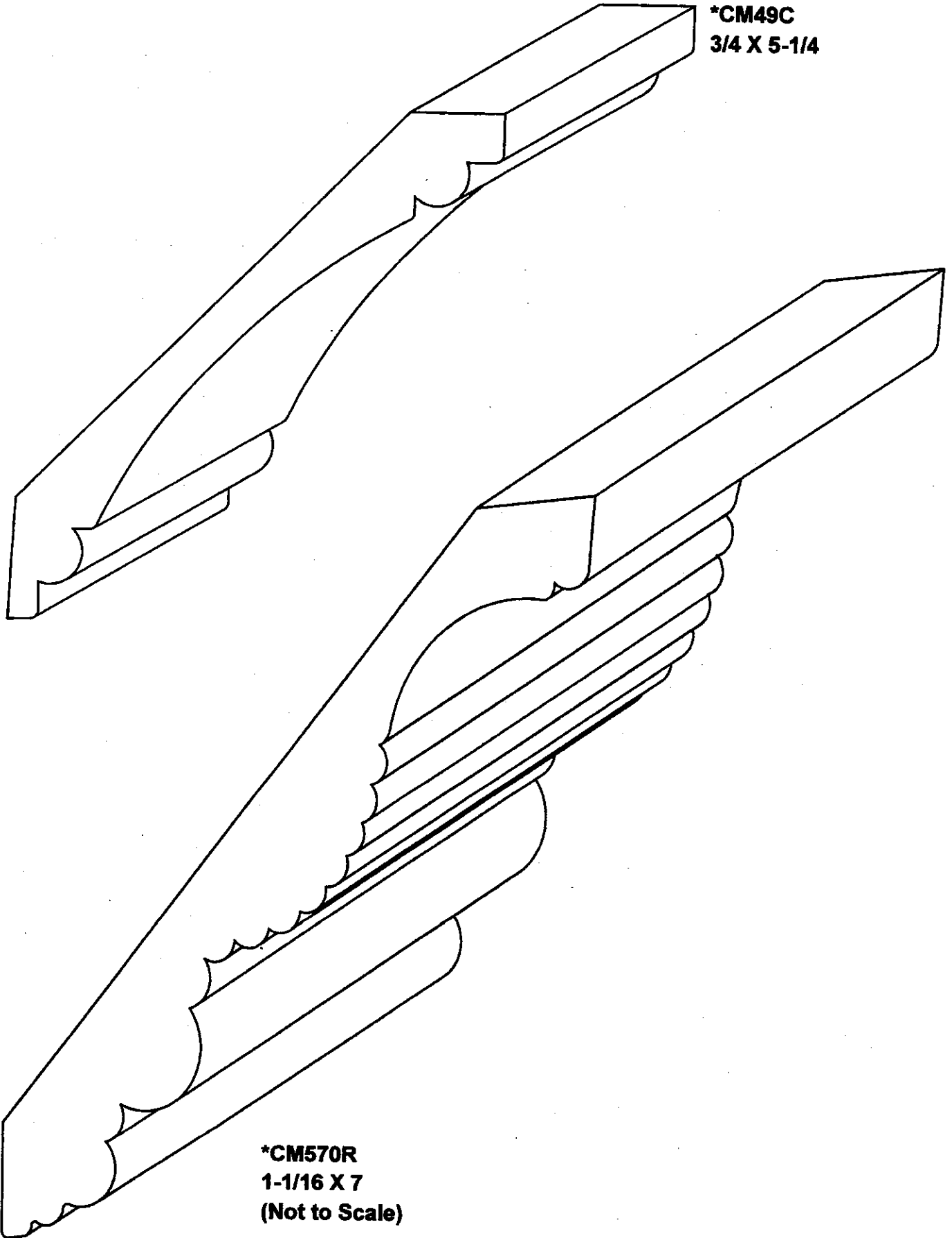

***CM49C**
3/4 X 5-1/4

***CM570R**
1-1/16 X 7
(Not to Scale)

Custom Crowns

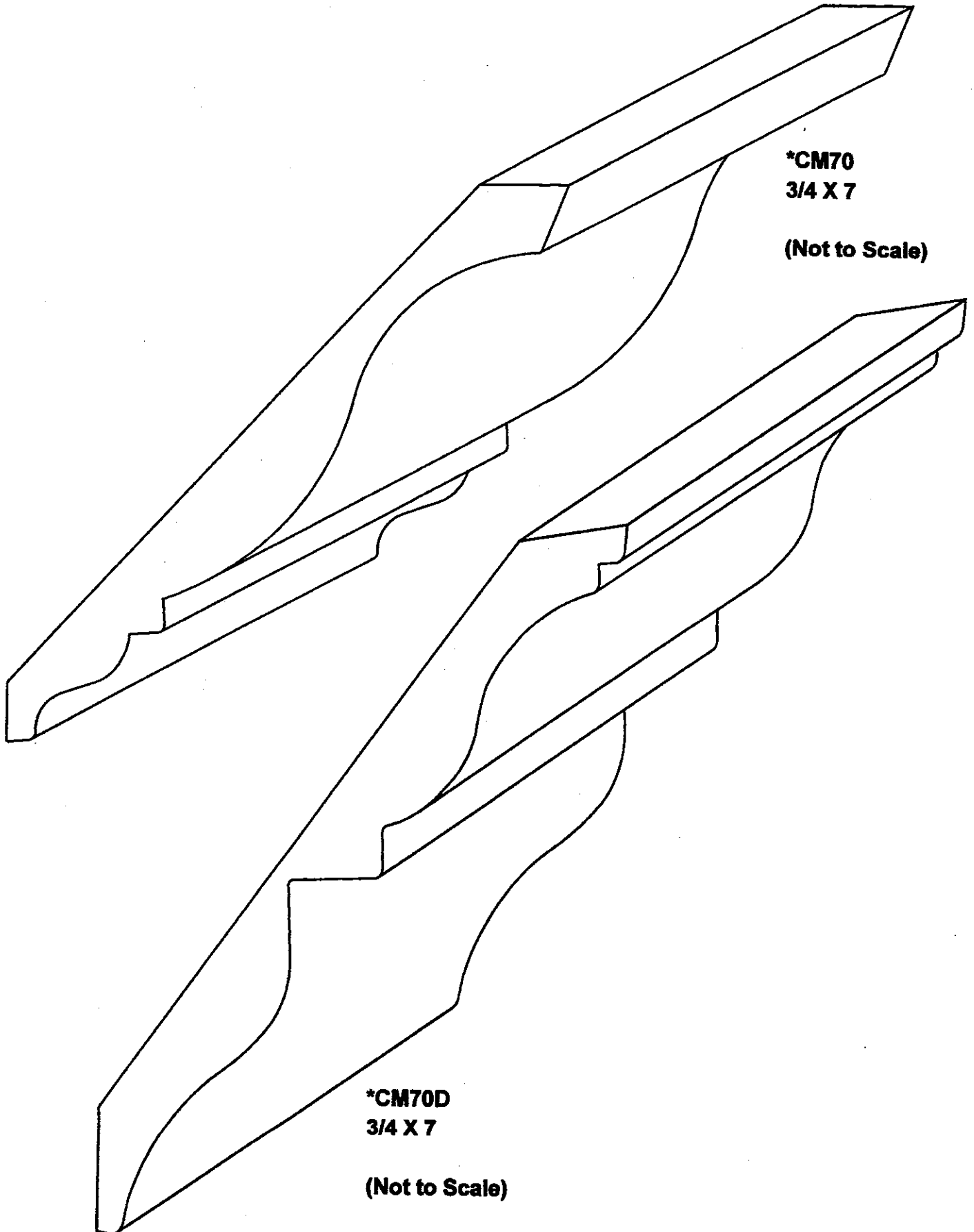

***CM70
3/4 X 7**

(Not to Scale)

***CM70D
3/4 X 7**

(Not to Scale)

*Special Run

Custom Chair Rails

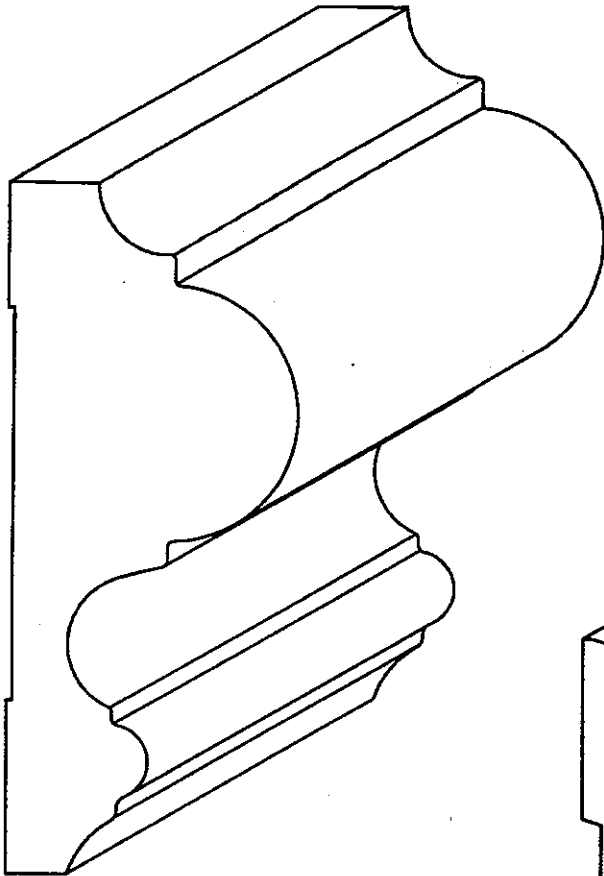

***CR325**
1-1/2 X 3-1/2

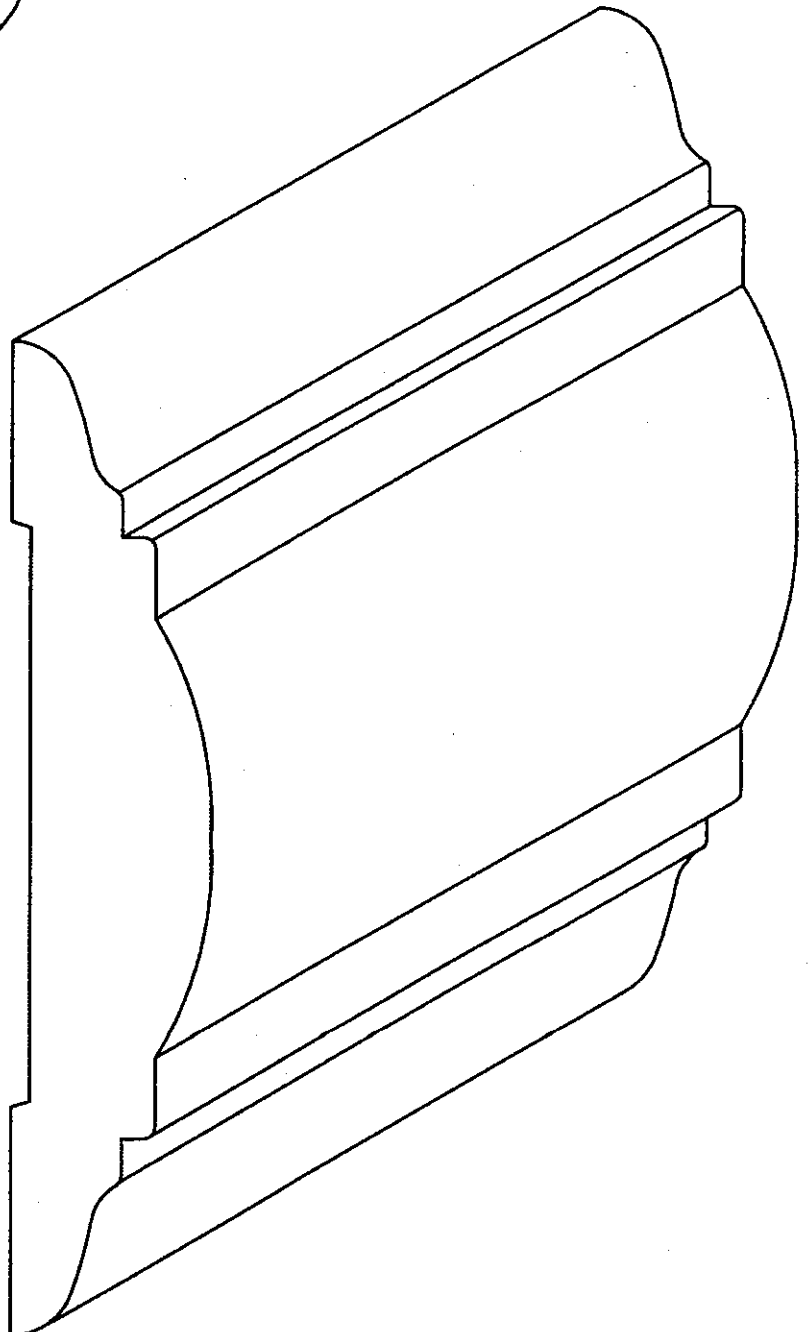

***CR560**
1 X 5

Custom Chair Rails

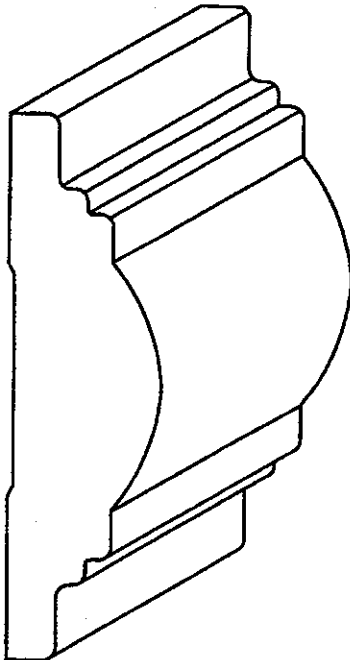

***CR275**
3/4 X 2-3/4

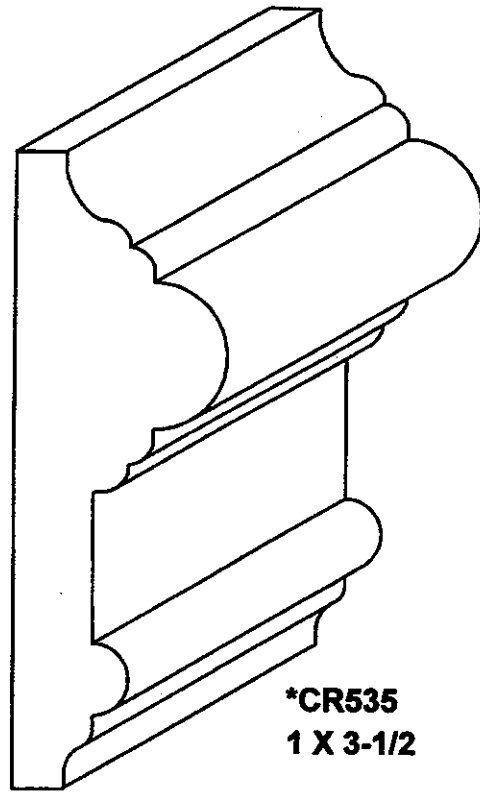

***CR535**
1 X 3-1/2

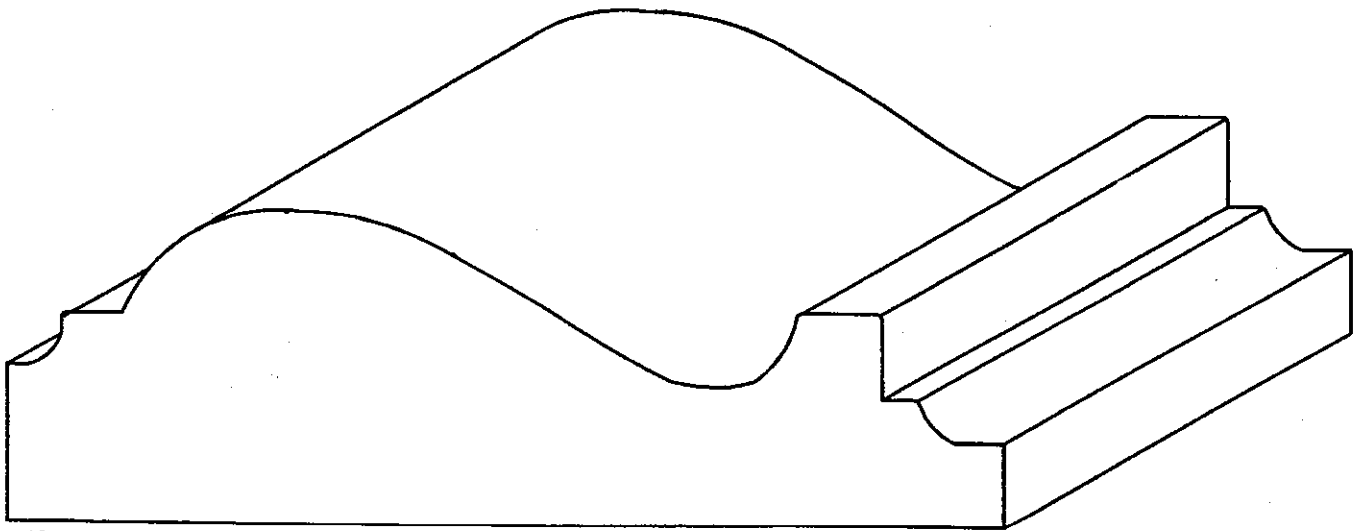

***MM525**
1-3/4 X 5-1/16

Custom Panel Molds

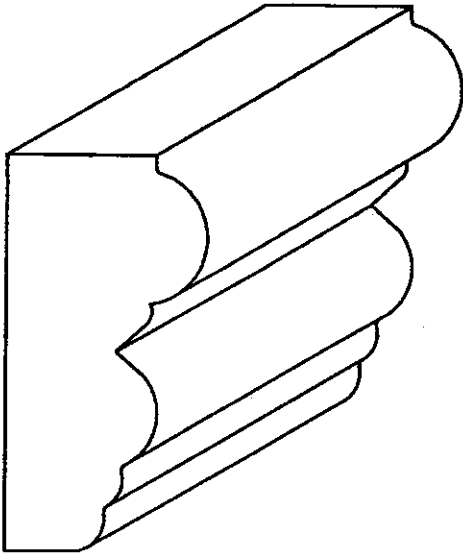

***PM216**
1 X 2

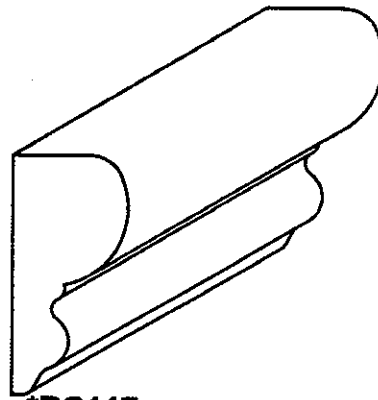

***BC117**
9/16 X 1-1/4

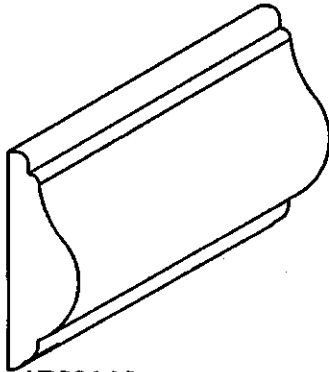

***BM118**
3/8 X 1-1/8

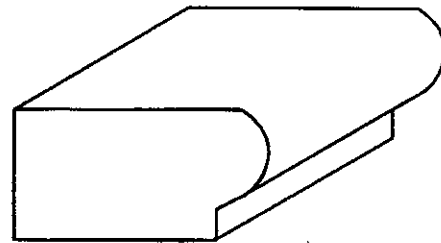

***WC114**
5/8 X 1-1/4

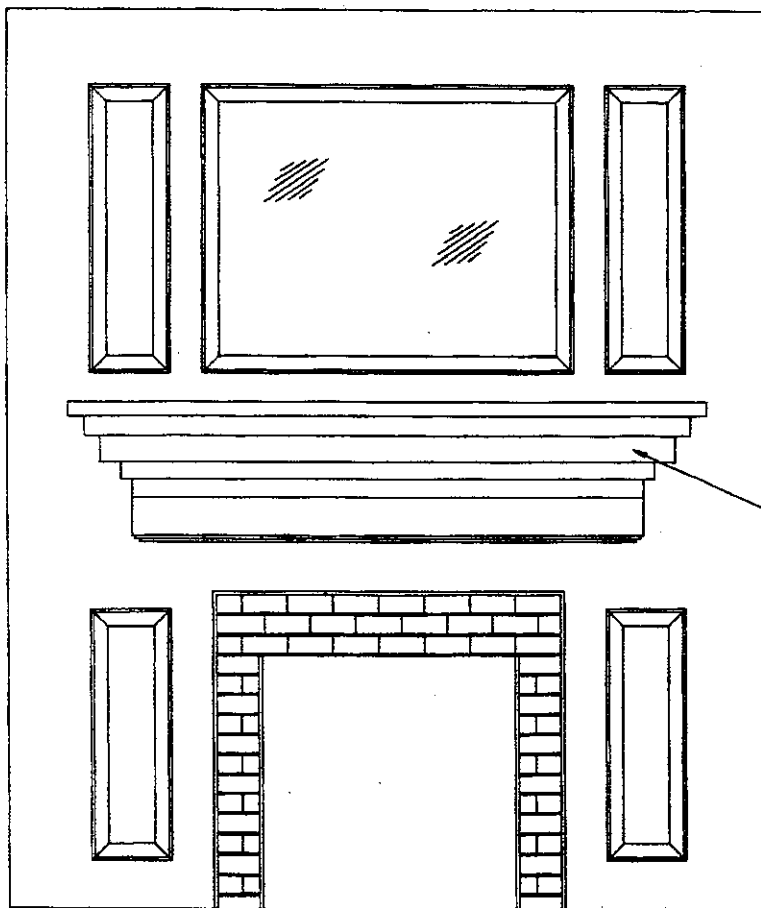
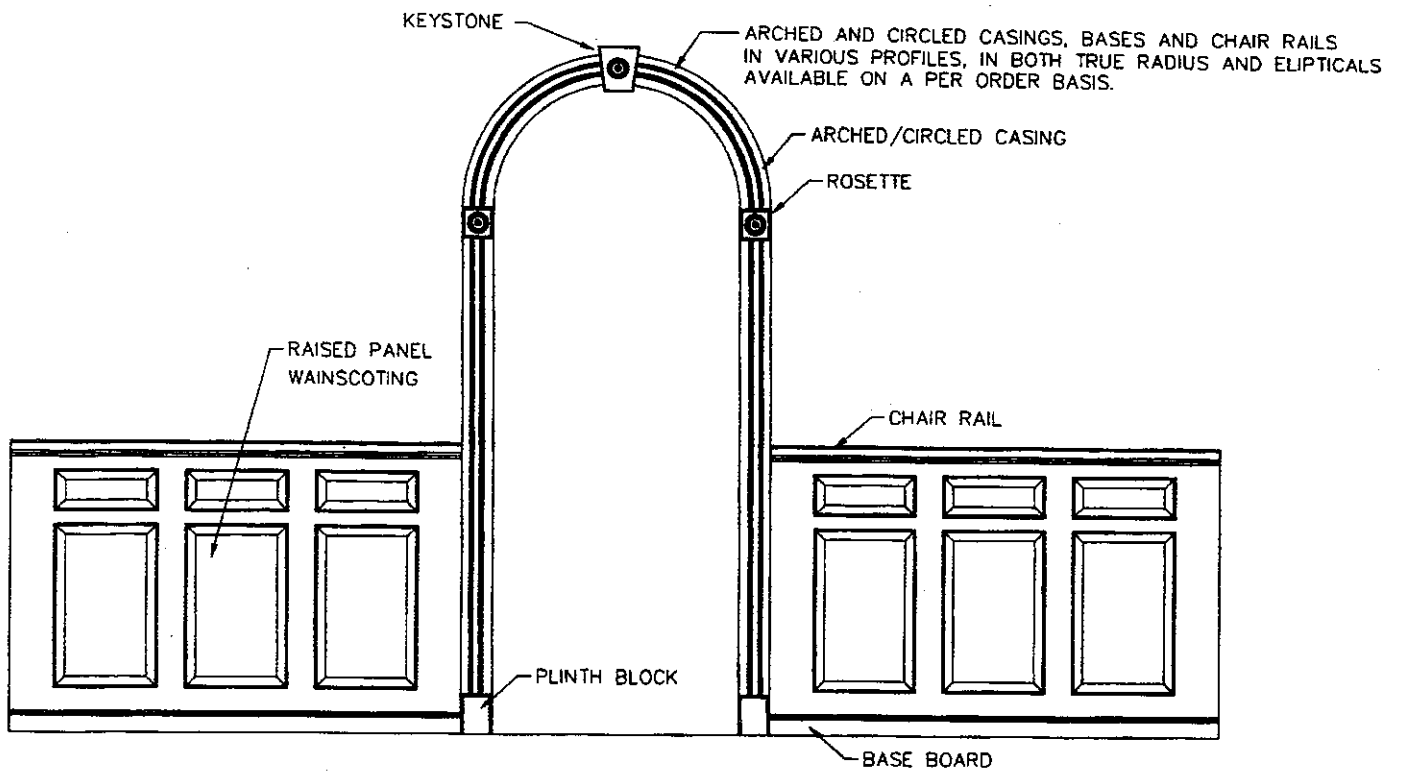

MANTELS
 A WIDE ASSORTMENT OF MANTELS
 ARE AVAILABLE. ASK YOUR LOCAL
 SALES REPRESENTATIVE FOR OUR
 MANTEL CATALOGUE.